

AU

# Belts for the Tyre Industry

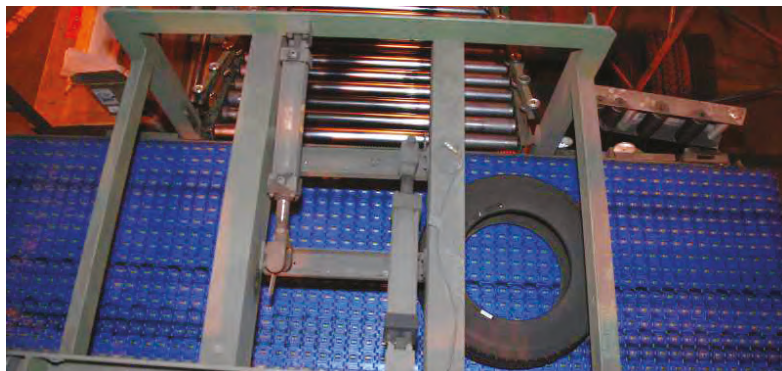



## Knowing your production process

### Specialist in your industry

Within the tyre industry, Ammeraal Beltech has been setting the standard for many years with consistent high product quality and market specific features. Innovations over the years, close co-operation with customers and leading research institutions have resulted in a number of new concepts.

Ammeraal Beltech offers a wide range of belting solutions for:

- weighing and loading of chemicals and raw materials;
- mixing of the components;
- extrusion of mixed rubber into semi-finished products;
- cooling of the extruded rubber;
- calendaring with steel or textiles;
- liners for winding systems;
- rubber feeders for tyre building machines;
- collecting and sorting;
- inspection, trimming and logistics.

### Specific requirements

- High temperature resistance and excellent non-stick – Silam Belts
- No contamination of rubber with plastics – Synthetic Belts
- Strong and wear resistant – uni Modular Belts
- Excellent cooling in downstream applications – uni Flex SNB and uni Flex ASB uni Modular Belts
- For conveying of treads, sidewalls and body plies – Flexam and Ropanol Belts
- Easy and quick on-site installation – ZipLink® Belts
- Long lasting, non-fraying and easy closing – Amwind Liners
- Perfect synchronisation (multi start and stop) – Ultrasync Belts
- Excellent rolling with easy assembly – Snap Link uni RTB Belts
- High grip of finished tyres on inclines – Felt NPF Belts



### Meeting your requirements with uni Modular Belts RTB M1 in the tyre industry

- Low friction rollers in belt surface for gentle handling of products
- Rollers can be arranged to allow sideways transfer
- High efficiency by eliminating jams, line stoppages and product damage
- Easy replacement of modules and rollers
- High temperature resistance

Extended information on [www.ammeraalbeltech.com](http://www.ammeraalbeltech.com)





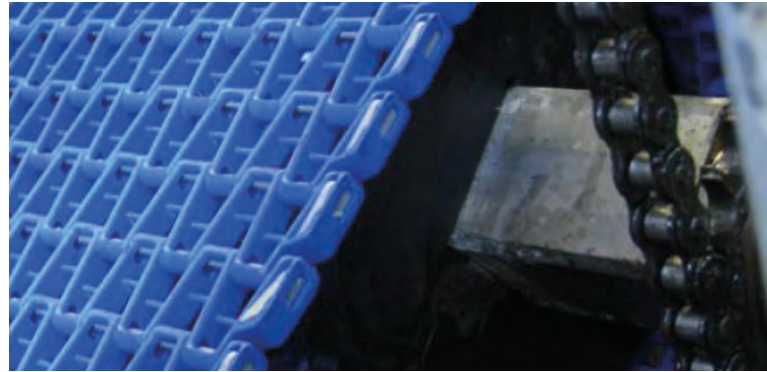

## Step one: preparation

With the unique product portfolio of fabric based Process and Conveyor Belts, as well as uni Modular Belts, Ammeraal Beltech provides the best technical belting solutions for the preparation part of tyre manufacturing.

### A Weighing and loading

Flexam Belts

- Good grip of raw materials on incline conveyors
- Different friction profiles available

uni QNB C Modular Belts, Rough and Rubber Top

- Strong, bi-directional belt for long conveyors
- Rough top non-slip surface
- Reduction of pulsation because of unique sprocket engagement
- Eliminating wear and increased friction properties for incline applications

### B Rubber mixing

Silam Belts

- Excellent release of sticky rubber
- Improved quality of rubber batch, no contamination of plastics with mixed rubber
- Avoid fibre contamination with Amseal or folded edges
- Heat resistant base materials
- Fasteners or ZipLink® Belt possible for easy assembly and less downtime

uni QNB Modular Belts in PA 6.6 – GFH

- Heat resistant up to 180 °C
- Cut resistant for batch separation
- Long lasting and low maintenance
- No tracking problems (bidirectional)

### B Rubber mixing

Fabric and Ropanol Belts

- Good release of sticky rubber
- Reliable process flow and low coefficient of friction
- Highly abrasive and cut resistant for reduced belt wear

### C Batch off

uni OWL Modular Belts in PA 6.6 – GFH

- Open structure (66%) for optimal soap / water recycling
- Minimum contact with rubber for maximum penetration of soap
- Strong belt with stainless steel pins
- Wear resistant material in combination with abrasive soap residue
- Split sprocket available for easy retrofit

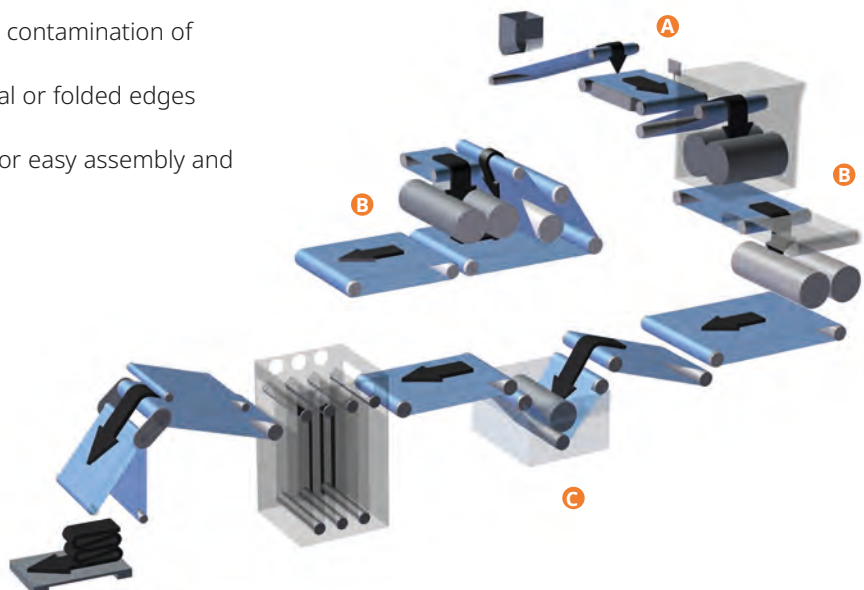

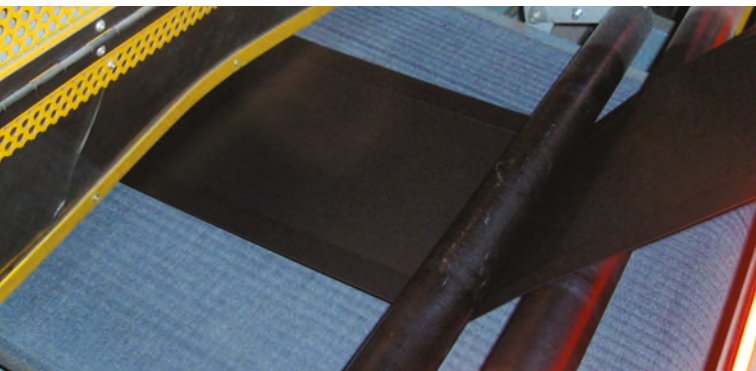

## Step two: confection

Ammeraal Beltech is able to offer a full range of high quality, lightweight Conveyor Belts in silicone, rubber, PVC and PU material for every step in your confection process.

### A Extrusion

Ropanol Belts

- Good release of mixed rubber because of impregnated top surface

uni QNB C Modular Belts

- Strong, bi-directional belt for long conveyors
- Reduction of pulsation because of unique sprocket engagement

Felt NPF 40 Belts

- Excellent friction on steep incline conveyors
- Cut resistant surface

### B Cooling

uni SNB 20% or 34% Modular Belts

- Less contact between belt and product for easy cooling of the rubber
- Unique lock-pin locking system enabling easy assembly and less downtime

### C Calendering

Felt NPF 40 Belts

- Excellent friction on steep incline conveyors
- Cut resistant surface

### D Cutting

Ropanyl Belts

- Longitudinally flexible for easy transfer of rubber between conveyors
- Abrasion resistant

### E Winding

AmWind Belts

- Frayless fabric to avoid fibre contamination
- Very long lifetime (huge quantities of winding cycles)
- Locking system available for turnkey liner system
- Non-stick properties (both sides)
- Lateral stability for easy winding
- Any colour possible

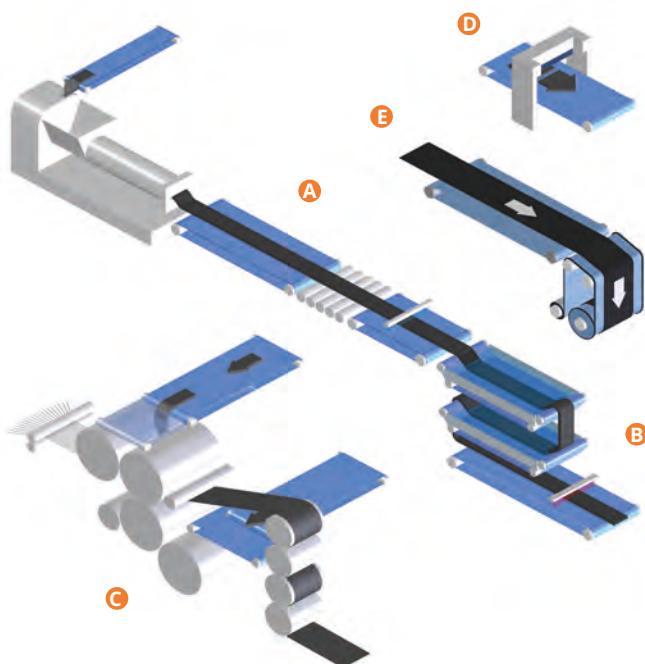

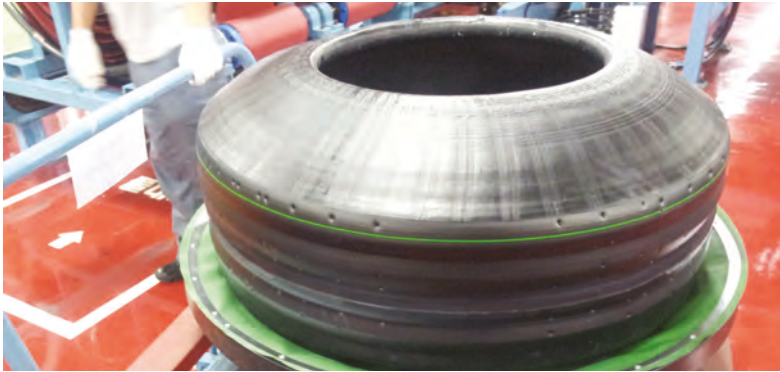

## Step three: finishing

Ammeraal Beltech is able to offer a full range of high quality, lightweight Conveyor Belts in silicone, rubber, PVC and PU material for every step of the finishing process.

### A Tyre building machines

Ropanol Belts

- Good release of sticky rubber
- Impregnated top and bottom to avoid fibre contamination

Ultrasync Belts

- Synchronised and precise positioning
- Non-stick properties for good release of rubber
- Grip covers available
- Splicing on site possible to reduce downtime

uni QNB C Modular Belts

- Strong, bi-directional belt for long conveyors
- Reduction of pulsation because of unique sprocket engagement

### B Curing, collecting and sorting

uni RTB M1 Modular Belts

- Low friction rollers in belt surface for gentle handling of products
- Rollers can be arranged to allow sideways transfer
- High efficiency by eliminating jams, line stoppages and product damage
- Easy replacement of modules and rollers
- High temperature resistance

Felt NPF 40 Belts

- Excellent grip for finished tyres on steep incline conveyors
- Gentle tyre handling to avoid damages

### C Trimming, inspection and logistics

uni RTB M1 and M2 Modular Belts

- Ability to handle many different tyre sizes without manual adjustments
- Easy replacement of modules and rollers
- Low friction rollers in belt surface for gentle handling of products
- Flexible roller positioning in six different angles

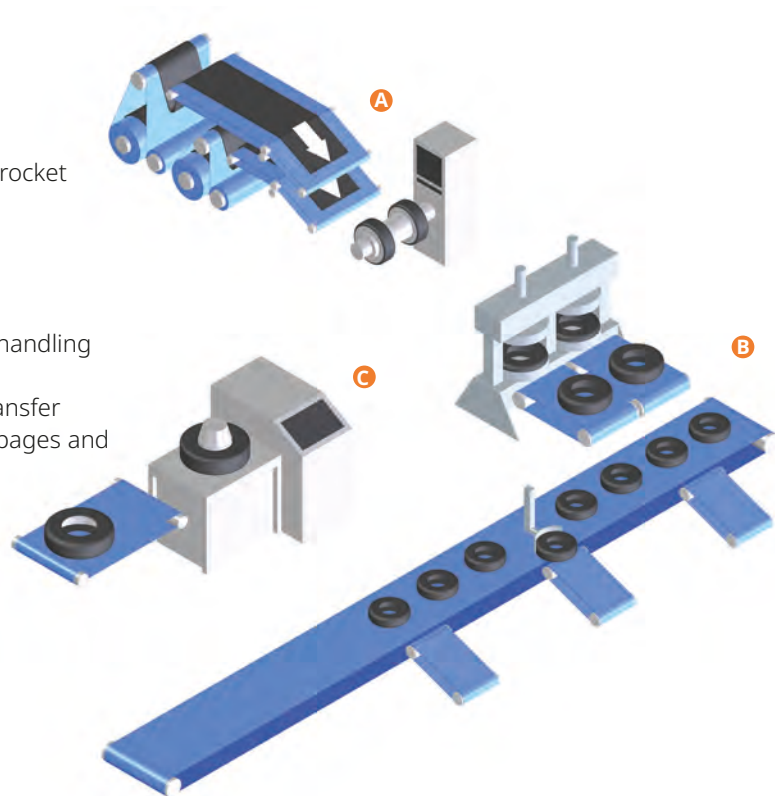



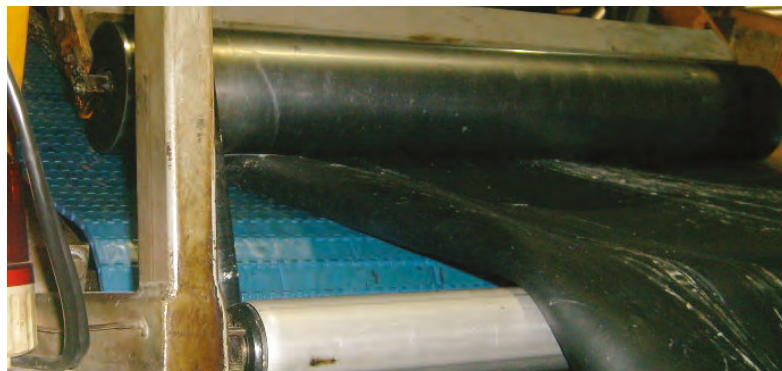

## Tyre concepts

Ammeraal Beltech is a leading manufacturer of process and conveyor belting with a long reputation for developing innovative solutions for belting applications.

### One Stop Belt Shop

Ammeraal Beltech is a global belting company and a true “One Stop Belt Shop”, able to provide the best belting solutions, components and services for processing and conveying of goods in the widest range of applications. Success is the control of the full value chain (development, manufacturing, fabrication, sales, distribution and service) and close co-operation with customers, suppliers and other partners.

### Sustainability

One of the corporate responsibilities is help to ensure a healthy environment for current and future generations. Part of the innovations focus on development of recyclable materials and long lasting solutions. For manufacturing of tyres, you can choose these sustainable solutions to contribute to your environmental goals.

### Energy Saving

Belt selection is a very important factor in saving energy, but not the only one. Three main factors influence power demand: motor efficiency, machine design and belt selection. Ammeraal Beltech therefore developed the ‘Energy Saving Concept’. By choosing the right belt, optimizing the design of the conveyor and using the right drive, energy can be saved during daily manufacturing of tyres.

### Safety

The contact between a car and the road is only a small patch of rubber. The quality of the tyre must be high and homogeneous to secure safety. The plastics Ammeraal Beltech uses in conveyor belts are not contaminating with uncured rubber. Also material handling during the process reduces the risk of damaging the rubber. Selecting the right belt for each application contributes to the reduction of risks.

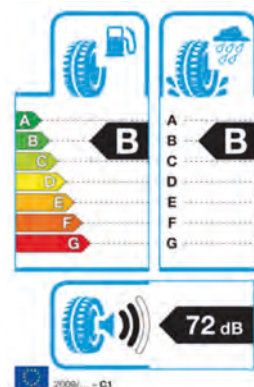
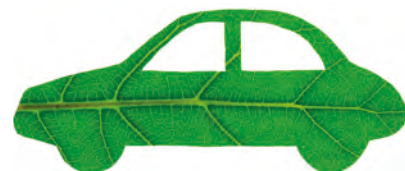

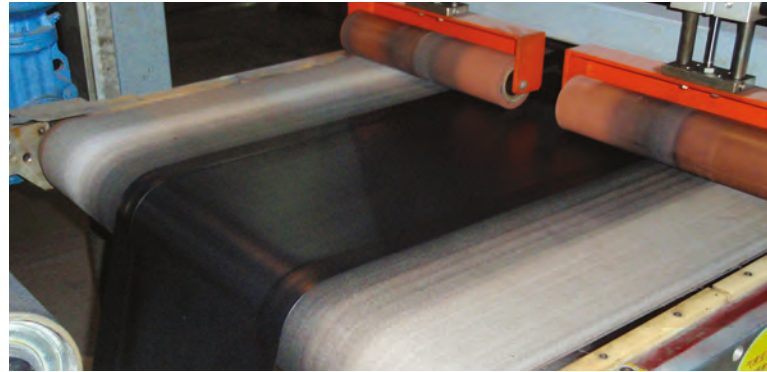
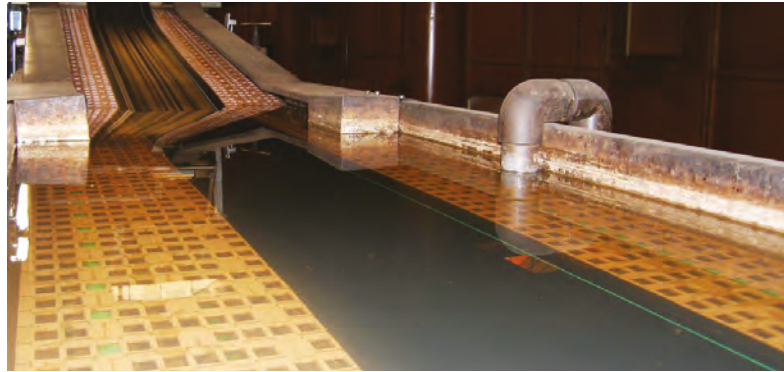

## Just-in-time delivery

Ammeraal Beltech is one of the world's leaders in process and conveyor belting with a worldwide distribution and service network in more than 150 countries.

Ammeraal Beltech understands the importance of keeping your business running and knows how costly and disruptive downtime is.

A solid combination of geographical coverage, market segment knowledge and product management is the foundation of an innovative and service-oriented organization.

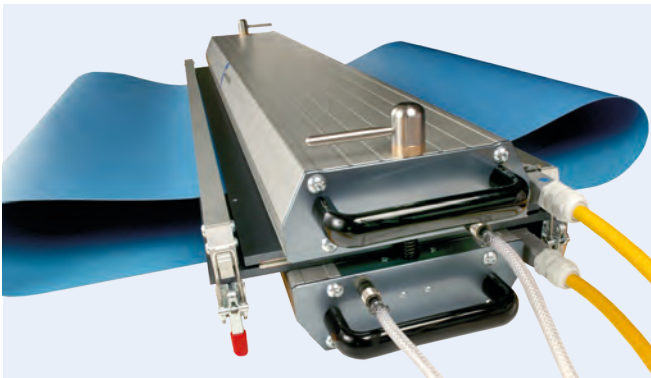

### **Excellent service, advice and fabrication**

- Ammeraal Beltech has developed a wide range of belting products and accessories to support and improve processes to secure a seamless operation.
- Skilled personnel are on call to install and service belts using high speed modern equipment.
- Most orders can be dispatched directly from stock.

**Extended information on  
[www.ammeraalbeltech.com](http://www.ammeraalbeltech.com)**

## Local Contacts

... and 150 more service contact points  
at [ammeraalbeltech.com/au](http://ammeraalbeltech.com/au)

### VICTORIA - Head Office & Administration

51 Bazalgette Crescent  
Dandenong South VIC 3175  
Ph (03) 8780 6000  
[salesvic@rydell.com.au](mailto:salesvic@rydell.com.au)

### QUEENSLAND - Modular Division

8 Machinery Street  
Darra QLD 4076  
Ph (07) 3564 4600  
[salesqld@rydell.com.au](mailto:salesqld@rydell.com.au)

### VIC - HASTINGS

Factory 16/24 Kanowna Street  
Hastings VIC 3915  
Ph (03) 5979 4447  
[salesvic@rydell.com.au](mailto:salesvic@rydell.com.au)

### NEW SOUTH WALES

22 Binney Road  
Kings Park NSW 2148  
Ph (02) 8664 9800  
[salesnsw@rydell.com.au](mailto:salesnsw@rydell.com.au)

### SOUTH AUSTRALIA

17-19 Churchill Road North  
Dry Creek SA 5094  
Ph (08) 8216 7000  
[salessa@rydell.com.au](mailto:salessa@rydell.com.au)

### NEW SOUTH WALES

New England/North West Region  
43 Macleay Way  
Invergowrie NSW 2350  
Ph 0418 513 998  
[salesnsw@rydell.com.au](mailto:salesnsw@rydell.com.au)

### QUEENSLAND

12 Machinery Street  
Darra QLD 4076  
Ph (07) 3564 4600  
[salesqld@rydell.com.au](mailto:salesqld@rydell.com.au)

### WESTERN AUSTRALIA

29 Irvine Drive  
Malaga WA 6090  
Ph (08) 9249 3777  
[saleswa@rydell.com.au](mailto:saleswa@rydell.com.au)

### VIC - BAIRNSDALE

Factory 3/79 Macleod Street  
Bairnsdale VIC 3875  
Ph 0487 555 118  
[salesvic@rydell.com.au](mailto:salesvic@rydell.com.au)

**Expert advice, quality solutions  
and local service  
for all your belting needs**

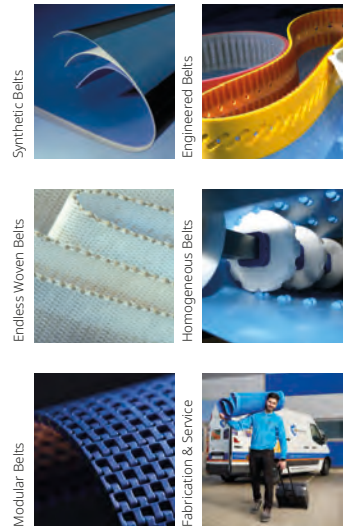

45+ years servicing Australia | 10 sales & services centres | Australia's One-Stop Belt Shop

### General contact information:

#### Ammeraal Beltech

P.O. Box 38  
1700 AA Heerhugowaard  
The Netherlands

T +31 (0)72 575 1212  
[info@ammeraalbeltech.com](mailto:info@ammeraalbeltech.com)

**ammega.com**