



**Your business  
is our business!**

## Belts for the Tire Industry

### Ammeraal Beltech

- knows your process
- for all your belting needs
- just-in-time delivery



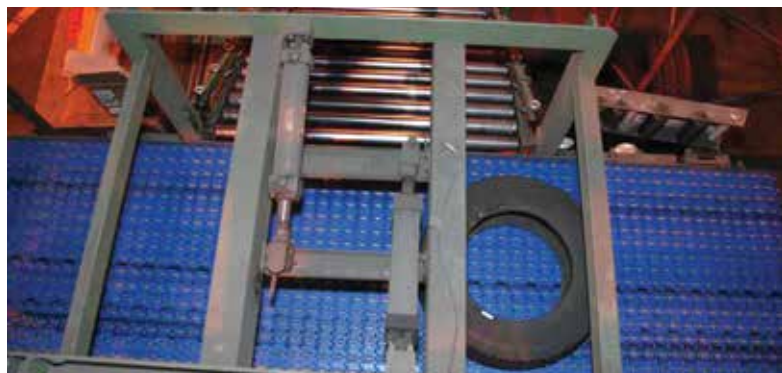

## Knowing your production process

### Specialist in your industry

Within the tire industry, Ammeraal Beltech has been setting the standard for many years with consistent high product quality and market-specific features. Innovations over the years, close cooperation with customers and leading research institutions have resulted in a number of new concepts.

Ammeraal Beltech offers a wide range of belting solutions for:

- › weighing and loading of chemicals and raw materials
- › mixing of the components
- › extrusion of mixed rubber into semi-finished products
- › cooling of the extruded rubber
- › calendaring with steel or textiles
- › liners for winding systems
- › rubber feeders for tire building machines
- › collecting and sorting
- › inspection, trimming and logistics



### Specific requirements

- › High temperature resistance and excellent non-stick – Silam Belts
- › No contamination of rubber with plastics – Synthetic Belts
- › Strong and wear resistant – uni Modular Belts
- › Excellent cooling in downstream applications – uni Flex SNB and uni Flex ASB uni Modular Belts
- › For conveying of treads, sidewalls and body plies – Flexam and Ropanol Belts
- › Easy and quick on-site installation – ZipLink Belts
- › Long lasting, non-fraying and easy closing – Amwind Liners
- › Perfect synchronization (multi start & stop) – Ultrasync Belts
- › Excellent rolling with easy assembly – Snap Link uni RTB Belts
- › High grip of finished tires on inclines – Felt NPF Belts



### Meeting your requirements with uni Modular Belts RTB M1 in the tire industry

- Low friction rollers in belt surface for gentle handling of products
- Rollers can be arranged to allow sideways transfer
- High efficiency by eliminating jams, line stoppages and product damage
- Easy replacement of modules and rollers
- High temperature resistance

Extended information at [www.ammeraalbeltech.com](http://www.ammeraalbeltech.com)



## Step one: preparation

With the unique product portfolio of fabric based Process and Conveyor Belts, as well as uni-chains Modular Belts, Ammeraal Beltech provides the best technical belting solutions for the preparation part of tire manufacturing.

### A Weighing and loading

Flexam Belts

- » Good grip of raw materials on incline conveyors
- » Different friction profiles available

uni QNB C Modular Belts, Rough and Rubber Top

- » Strong, bi-directional belt for long conveyors
- » Rough top non-slip surface
- » Reduction of pulsation because of unique sprocket engagement
- » Eliminating wear and increased friction properties for incline applications

### B Rubber mixing

Silam Belts

- » Excellent release of sticky rubber
- » Improved quality of rubber batch, no contamination of plastics with mixed rubber
- » Avoid fiber contamination with Amseal or folded edges
- » Heat resistant base materials
- » Fasteners or ZipLink Belt possible for easy assembly and less downtime

uni QNB Modular Belts in PA 6.6 – GFH

- » Heat resistant up to 180°C (356°F)
- » Cut resistant for batch separation
- » Long lasting and low maintenance
- » No tracking problems (bidirectional)

### B Rubber mixing

Fabric and Ropanol Belts

- » Good release of sticky rubber
- » Reliable process flow and low coefficient of friction
- » Highly abrasive and cut resistant for reduced belt wear

### C Batch off

uni OWL, Modular Belts in PA 6.6 – GFH

- » Open structure (66%) for optimal soap/water recycling
- » Minimum contact with rubber for maximum penetration of soap
- » Strong belt with stainless steel pins
- » Wear resistant material counters abrasive soap residue
- » Split sprocket available for easy retrofit

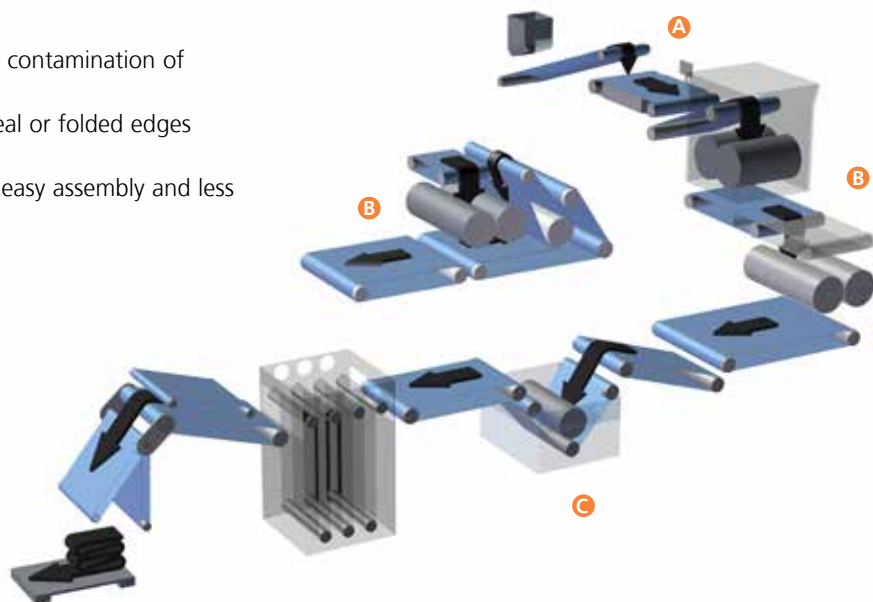



## Step two: fabrication

Ammeraal Beltech is able to offer a full range of high quality, lightweight Conveyor Belts in silicone, rubber, PVC and PU material for every step in your fabrication process.

### A Extrusion

Ropanol Belts

- » Good release of mixed rubber because of impregnated top surface

uni QNB C Modular Belts

- » Strong, bi-directional belt for long conveyors
- » Reduction of pulsation because of unique sprocket engagement

Felt NPF 40 Belts

- » Excellent friction on steep incline conveyors
- » Cut resistant surface

### B Cooling

uni SNB 20% or 34%, Modular Belts

- » Less contact between belt and product for easy cooling of the rubber
- » Unique lock-pin locking system enabling easy assembly and less downtime

### C Calendering

Felt NPF 40 Belts

- » Excellent friction on steep incline conveyors
- » Cut resistant surface

### D Cutting

Ropanyl Belts

- » Longitudinally flexible for easy transfer of rubber between conveyors
- » Abrasion resistant

### E Winding

AmWind Belts

- » Frayless fabric to avoid fiber contamination
- » Very long lifetime (huge quantities of winding cycles)
- » Locking system available for turnkey liner system
- » Non-stick properties (both sides)
- » Lateral stability for easy winding
- » Any color possible

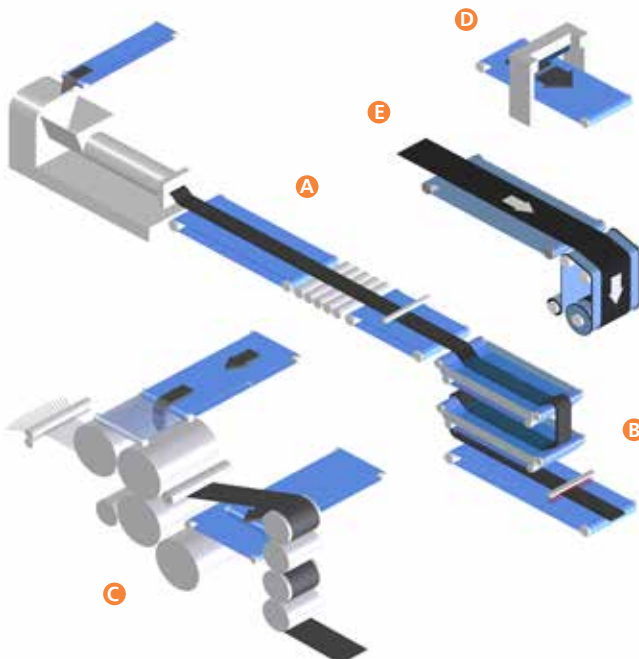

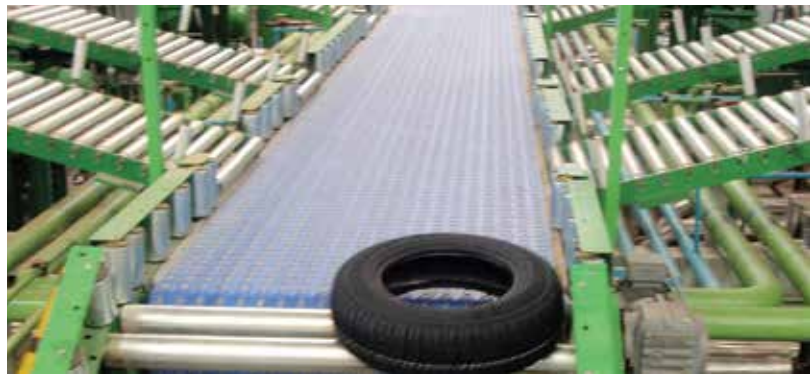
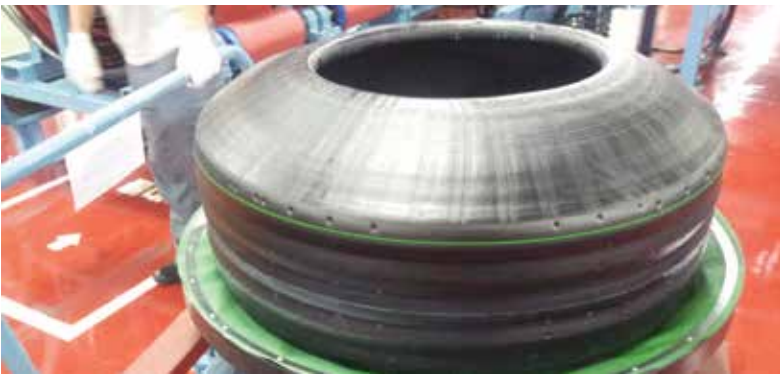

## Step three: finishing

Ammeraal Beltech is able to offer a full range of high quality, lightweight Conveyor Belts in silicone, rubber, PVC and PU material for every step of your finishing process.

### A Tire building machines

Ropanol Belts

- » Good release of sticky rubber
- » Impregnated top and bottom to avoid fiber contamination

Ultrasync Belts

- » Synchronized and precise positioning
- » Non-stick properties for good release of rubber
- » Grip covers available
- » Splicing on site possible to reduce downtime

uni QNB C, Modular Belts

- » Strong, bi-directional belt for long conveyors
- » Reduction of pulsation because of unique sprocket engagement

### B Curing, collecting and sorting

uni RTB M1, Modular Belts

- » Low friction rollers in belt surface for careful handling of products
- » Rollers can be arranged to allow sideways transfer
- » High efficiency by eliminating jams, line stoppages and product damage
- » Easy replacement of modules and rollers
- » High temperature resistance

Felt NPF 40 Belts

- » Excellent grip for finished tires on steep incline conveyors
- » Solid tire handling to avoid damages

### C Trimming, inspection and logistics

uni RTB M1 and M2, Modular Belts

- » Ability to handle many different tire sizes without manual adjustments
- » Easy replacement of modules and rollers
- » Low friction rollers in belt surface for careful handling of products
- » Flexible roller positioning in six different angles

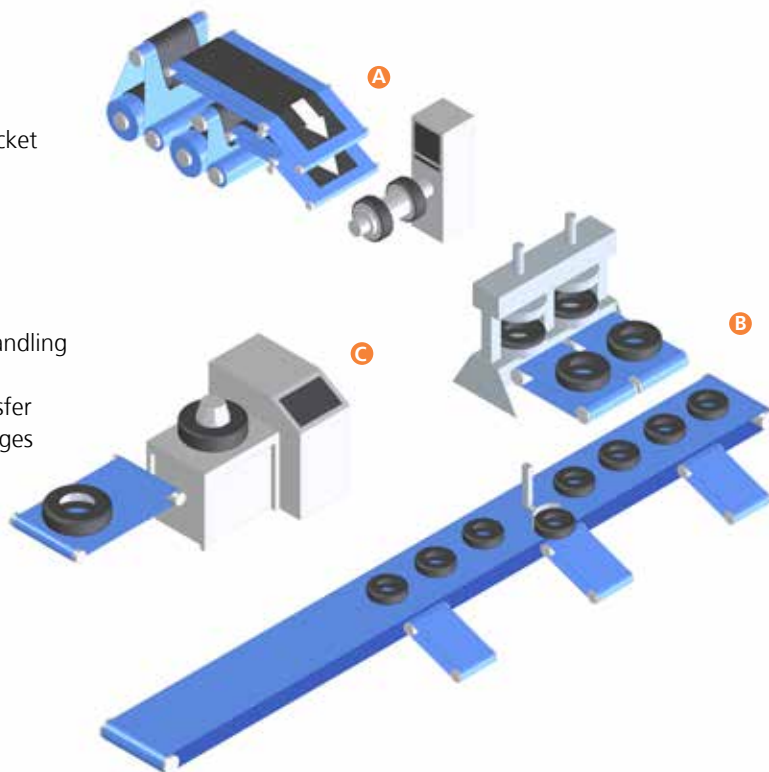



## Tire concepts

Ammeraal Beltech is a leading manufacturer of process and conveyor belting with a long reputation for developing innovative solutions for belting applications.

### One Stop Belt Shop

Ammeraal Beltech is a global belting company and a true “One Stop Belt Shop”, able to provide the best belting solutions, components, and services for processing and conveying of goods in the widest range of applications. Success is the control of the full value chain (development, manufacturing, fabrication, sales, distribution and service) and close cooperation with customers, suppliers and other partners.

### Sustainability

One of our corporate responsibilities is help to ensure a healthy environment for current and future generations. Part of the innovations focus on development of recyclable materials and long lasting solutions. For manufacturing of tires, you can choose these sustainable solutions to contribute to your environmental goals.

### Energy Saving

Belt selection is a very important factor in saving energy, but not the only one. Three main factors influence power demand: motor efficiency, machine design, and belt selection. Ammeraal Beltech therefore developed the ‘Energy Saving Concept’.

By choosing the right belt, optimizing the design of the conveyor and using the right drive, energy can be saved during daily manufacturing of tires.

### Safety

The contact between a car and the road is only a small patch of rubber. The quality of the tire must be high and homogeneous to secure safety. The plastics Ammeraal Beltech uses in conveyor belts do not contaminate uncured rubber. Also material handling during the process reduces the risk of damaging the rubber. Selecting the right belt for each application contributes to the reduction of risks.

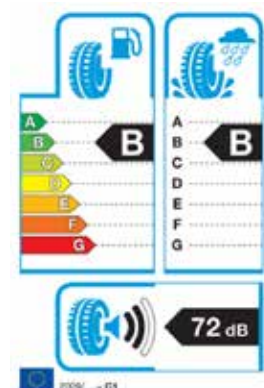

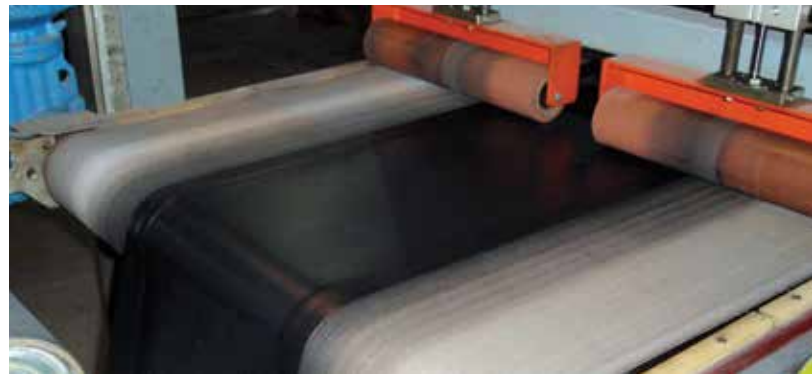

## Just-in-time delivery

**Ammeraal Beltech is one of the world's leaders in process and conveyor belting with a worldwide distribution and service network in more than 150 countries.**

Ammeraal Beltech understands the importance of keeping your business running and knows how costly and disruptive downtime is.

A solid combination of geographical coverage, market segment knowledge and product management is the foundation of our innovative and service-oriented organization.

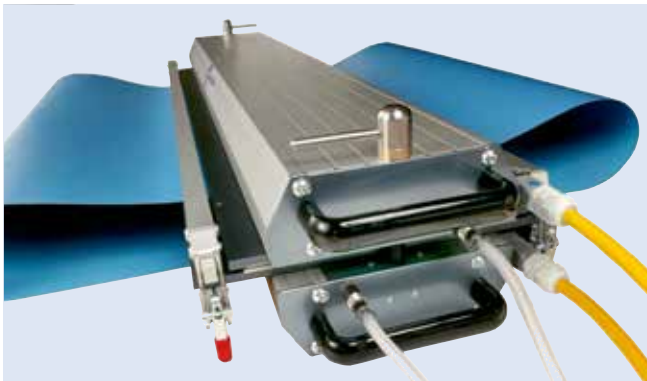

### **Excellent service, advice and fabrication**

- Ammeraal Beltech has developed a wide range of belting products and accessories to support and improve processes to secure a seamless operation.
- Skilled personnel are on call to install and service belts using high speed modern equipment.
- Most orders can be dispatched directly from stock.

**Extended information at [www.ammeraalbeltech.com](http://www.ammeraalbeltech.com)**

# US Sales and Service Locations

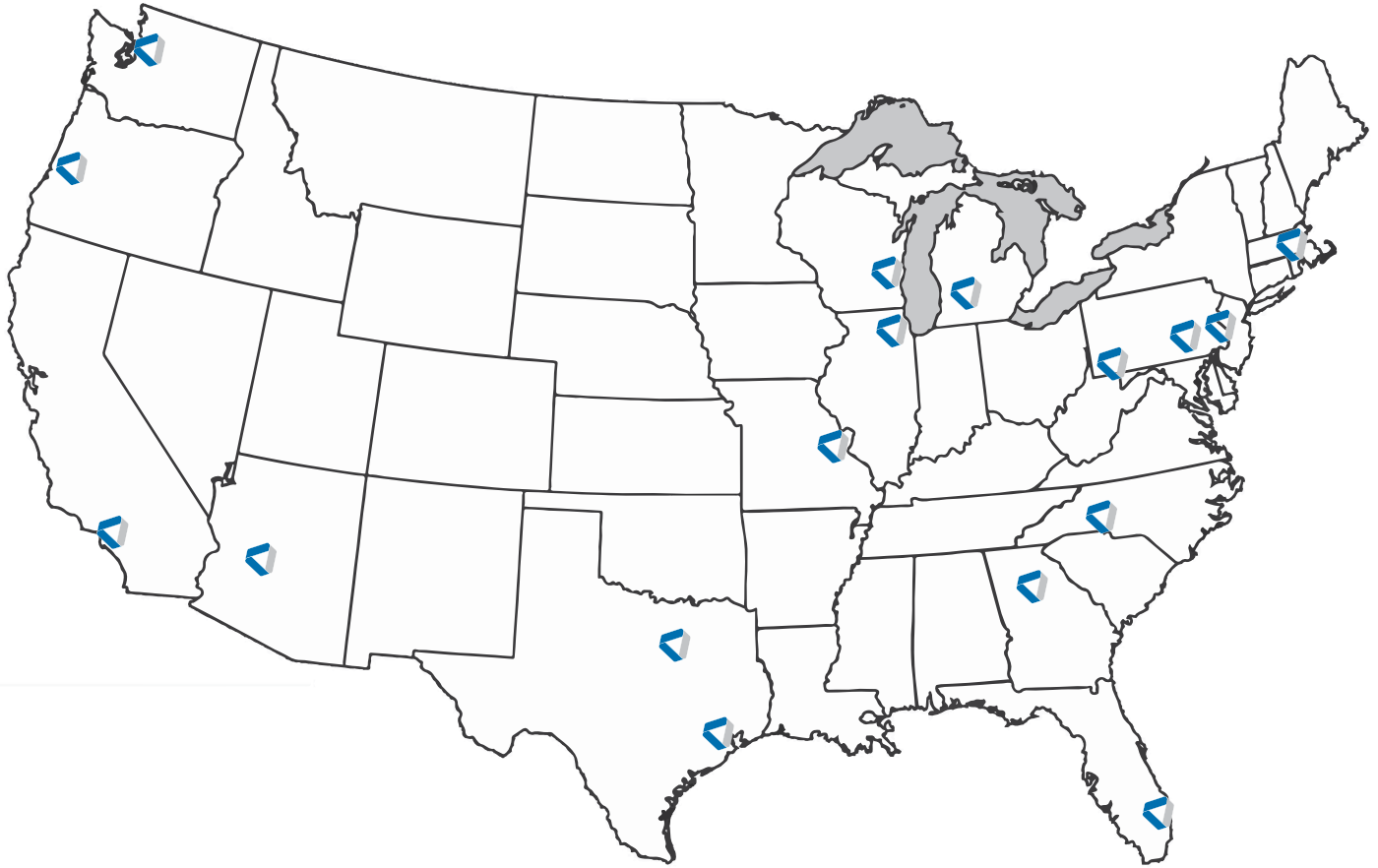

Expert advice, quality solutions  
and local service  
for all your belting needs

## SYNTHETIC

### Ammeraal Beltech North America

7501 N. St. Louis Avenue  
Skokie, IL 60076

T +1 847 673 6720  
F +1 847 673 6373  
TF +1 800 323 4170

info-us@ammeraalbeltech.com  
www.ammeraalbeltech.com

## MODULAR

### Ammeraal Beltech North America

500 Brentwood Drive  
Reading, PA 19611

T +1 610 372 1800  
F +1 610 372 3590  
TF +1 800 937 2864

info-us@ammeraalbeltech.com  
www.ammeraalbeltech.com

## SPECIALTIES

### Ammeraal Beltech North America

112 Nardis Drive  
Jefferson, PA 15344

T +1 847 673 6720  
F +1 847 673 6373  
TF +1 800 323 4170

info-us@ammeraalbeltech.com  
www.ammeraalbeltech.com



Conveyor Belts

Timing Belts



Seamless Belts

Transmission Belts



Modular Belts

Fabrication & Service

... and 150 more service contact points at [www.ammeraalbeltech.com](http://www.ammeraalbeltech.com)