

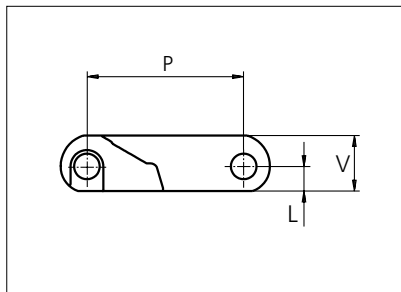

Plastic Modular Belt

Series **uni CPB** Type **C**



Straight running belt
 Nominal pitch: 50.8 mm (2.00 in)
 Surface type: Flat
 Surface opening: Closed
 Backflex radius: 85.0 mm (3.30 in)
 Pin diameter: 8.0 mm (0.31 in)

Belt material & color	POM-NL K	PP G	mm	in	mm	in		
			P (Nominal)	50.8	2.00	V	19.0	0.75
Pin material & color	PA6.6 N		L	8.0	0.31	-	-	-

Non standard material and color: See uni Material and Color Overview.
 Alternative pin and lock systems and materials: Contact Customer Service.

Belt width		Permissible tensile force (Belt/pin material)				Belt weight (Belt/pin material)				*Min. No. drive sprocket per shaft	Number of wear strips (Min. No.)	
		POM-NL / PA6.6		PP/PA6.6		POM-NL / PA6.6		PP/PA6.6			**Carry (pcs)	**Return (pcs)
mm	in	N	lbf	N	lbf	kg/m	lb/ft	kg/m	lb/ft			
151	5.9	7852	1765	5285	1188	2.5	1.68	1.7	1.13	2	2	2
202	8.0	10504	2361	7070	1589	3.4	2.25	2.2	1.51	2	2	2
252	9.9	13104	2946	8820	1983	4.2	2.81	2.8	1.88	2	2	2
302	11.9	15704	3530	10570	2376	5.0	3.37	3.4	2.25	3	3	2
352	13.9	18304	4115	12320	2770	5.8	3.93	3.9	2.63	3	3	2
403	15.9	20956	4711	14105	3171	6.7	4.50	4.5	3.01	3	3	2
453	17.8	23556	5295	15855	3564	7.5	5.05	5.0	3.38	4	4	2
503	19.8	26156	5880	17605	3958	8.3	5.61	5.6	3.75	4	4	2
553	21.8	28756	6464	19355	4351	9.2	6.17	6.1	4.13	4	4	2
604	23.8	31408	7061	21140	4752	10.0	6.74	6.7	4.51	5	5	3
654	25.7	34008	7645	22890	5146	10.9	7.30	7.3	4.88	5	5	3
704	27.7	36608	8229	24640	5539	11.7	7.85	7.8	5.25	5	5	3
754	29.7	39208	8814	26390	5932	12.5	8.41	8.4	5.62	6	6	3

Additional standard belt widths are available in steps of 50.3 mm (1.98 in). Additional non-standard belt widths are available in steps of mm 16.8 (0.66 in).

1961	77.2	101972	22923	68635	15429	32.6	21.88	21.8	14.63	14	14	7
------	------	--------	-------	-------	-------	------	-------	------	-------	----	----	---

Additional standard belt widths are available in steps of 50.3 mm (1.98 in). Additional non-standard belt widths are available in steps of mm 16.8 (0.66 in).

2966	116.8	154232	34671	103810	23336	49.2	33.09	32.9	22.13	20	20	10
------	-------	--------	-------	--------	-------	------	-------	------	-------	----	----	----

General belt tolerance is +0/-0.4% at 23°C/73°F and 50% RH. For exact belt width contact Customer Service. Non standard belt width on request.

*Max. Load per Drive Sprocket. Belt material: POM-NL 2500 N (560 lbf). PP 2500 N (560 lbf).

**Max. Spacing between wear strips. Carry: 152.0 mm (6.00 in); Return: 304.0 mm (12.00 in).

= Single Link



STANDARD

STRAIGHT RUNNING

PITCH 50.8 MM/2.00 IN

Accessories

Rubber Top

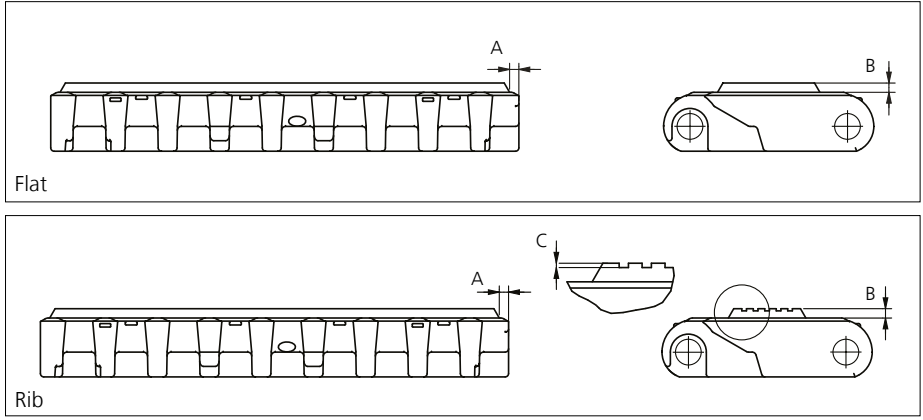

Type	Belt material & color	Rubber material & color	A		B		C		Link size	Width	
			mm	in	mm	in	mm	in		mm	in
Flat	POM-NL K	09 K	2.5	0.09	3.0	0.12	0.7	0.02	K600	150.5	5.93
Rib											

The color of standard rubber material is black. However, as it is hardly possible to see black rubber on black links, the links are illustrated with rubber in color natural. Other Non Standard Rubber profiles: See uni Rubber Profile Overview.

Accessories

Flight

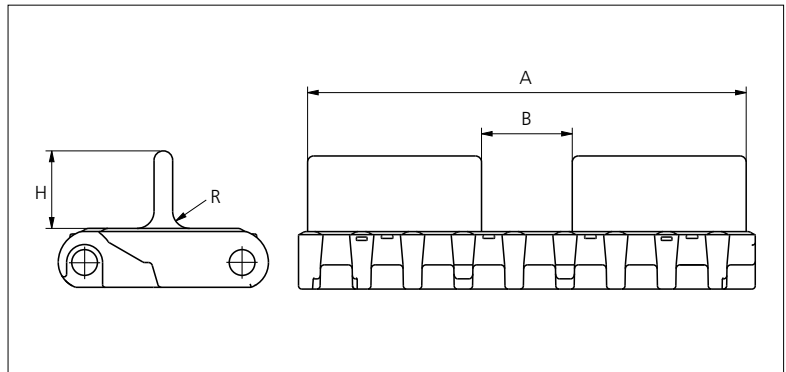

Type	Material & color	H		R		A		B		Link size	Width		Indent	
		mm	in	mm	in	mm	in	mm	in		mm	in	mm	in
Flat	POM-NL K	25.0	0.98	5.5	0.22	145.0	5.70	30.0	1.18	K600	150.5	5.93	2.8	0.11

Non Standard material and color: See uni Material and Color Overview.

Accessories

Top/Bottom Insert NON STANDARD



The thread inserts allow for easy attachment of fixturers to the belt. Available insert size M5 + M6.

Depending on the size and shape of the attachment, attention should be paid as to how it will influence on the backflex radius of the belt.

Accessories

AmFlight

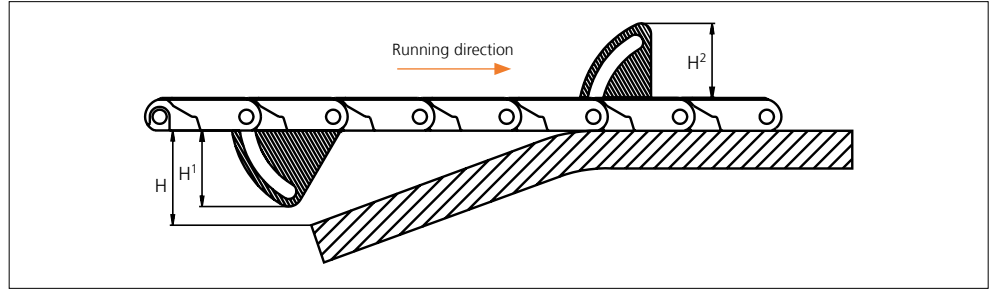
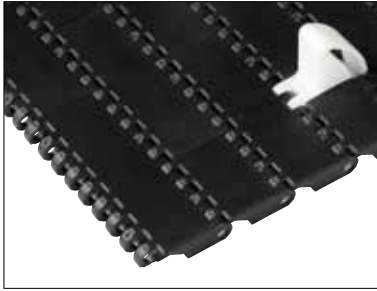

Type	Material & color	H		H ¹		H ²	
		mm	in	mm	in	mm	in
Pull	PE W	56.2	1.21	45.0	1.77	45.6	1.80

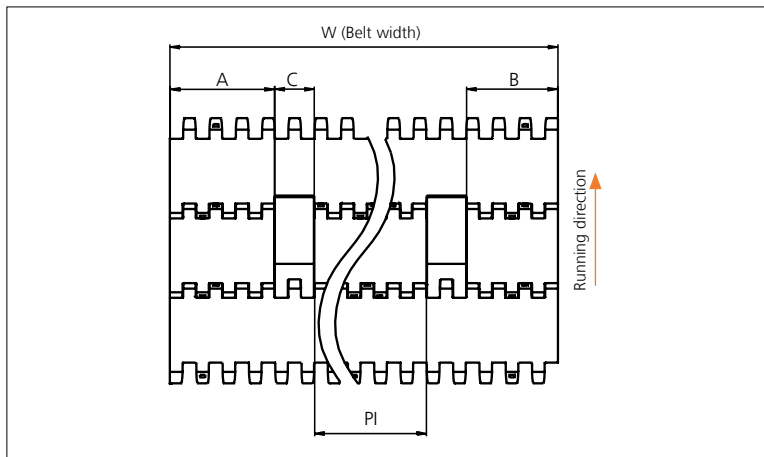

	mm	in
A min	67.7	2.67
B min	59.3	2.33
C	24.0	0.94
PI max	W - 175.0	W - 6.89
PI min	43.2	1.70

Increment: 17.0 mm (0.70 in.)

Sprocket

No of teeth	Bore size										Overall diameter		Pitch-diameter		Hub-diameter		Dimension A		Dimension B		Single row/One way	Double row/Two way	Molded PA6 LG	Machined PA6 N
	Pilot bore		1.00		1.18		1.25		1.50															
	mm	in	25.4	30.0	31.8	38.1	40.0	60.0	63.5	90.0	mm	in	mm	in	mm	in	mm	in						
Z06	✓	●	●	●	■	●	■				99.5	3.92	101.6	4.00	65.0	2.56	36.0	1.42	59.3	2.33	✓		✓	
Z08	✓	●	●	●	■	●	■	■			132.9	5.23	132.8	5.23	70.0	2.75	53.3	2.10	74.9	2.94	✓	1✓	✓	
Z10	✓		1●	1●	1●	1■	1■	2■	2■		166.3	6.55	164.4	6.47	¹ 70.0 ² 120.0	2.75 4.72	70.2	2.76	90.7	3.57	✓	✓	✓	
Z12	✓		1●	1●	1●	1■	1■	2■	2■	3■	198.6	7.82	196.3	7.73	¹ 70.0 ² 120.0 ³ 164.0	2.75 4.72 6.45	86.8 86.8	3.42 3.42	106.6 106.6	4.19 4.19	¹⁺² ✓	²⁺³ ✓	✓	
Z16	✓		2● 1●	2● 1●	2● 1●	2■ 1■	2■ 1■	3■ 1■	2■ 1■	3■	263.8	10.39	260.4	10.25	¹ 150.0 ² 164.0 ³ 200.0	5.90 6.45 7.87	119.7	4.71	138.7	5.46	1✓	²⁺³ ✓	✓	✓

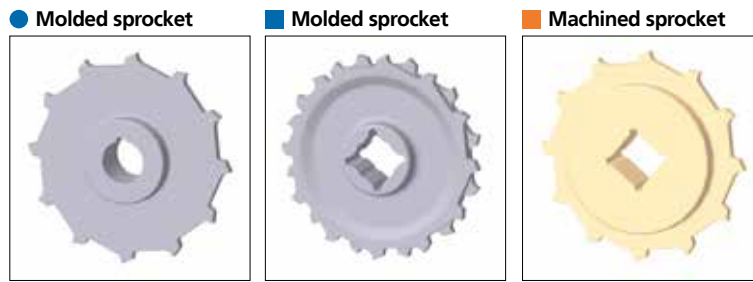

Other sprocket sizes are available upon request.
 Other bore sizes on sprockets are available upon request.
 Round bores are always delivered with keyway.
 Max. load per sprocket shown does not take bore size into account.
 Please also ensure that sufficient size shaft is chosen for corresponding load.

Width of tooth = Single row: 9.5 mm (0.37 in)
 = Double row: 17.8 mm (0.70 in)

Width of One-part sprocket = Single row: 42.3 mm (1.66 in)
 = Double row: 42.3 mm (1.66 in)
 = ³Double row: 50.0 mm (1.96 in)

uni UltraClean Two-Part Sprocket

No. of teeth	Bore size				Overall diameter		Pitch-diameter		Hub-diameter		Dimension A		Dimension B		Single row/One way	Moulded PA6 W
	in	1.50	1.57	2.36												
	mm	38.1	40.0	60.0	mm	in	mm	in	mm	in	mm	in				
Z8		■	■		132.9	5.23	132.8	5.23	80.0	3.15	53.3	2.10	74.9	2.94	✓	✓
Z10		1■	1■	2■	166.3	6.55	164.4	6.47	¹ 126.0 ² 118.0	¹ 4.96 ² 4.65	70.2	2.76	90.7	3.57	✓	✓
Z12		1■	1■	2■	198.6	7.82	196.3	7.73	¹ 126.0 ² 118.0	¹ 4.96 ² 4.65	86.8	3.42	106.6	4.19	✓	✓

Moulded uni UltraClean TwoPart Sprocket

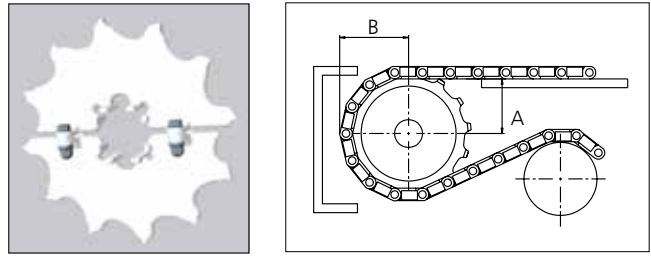

Width of UltraClean Two-part sprocket = Single row: 44.0 mm (1.73 in)
 Width of UltraClean Two-part sprocket, tooth = Single row: 9.5 mm (0.37 in)

uni Retainer Rings: See uni Retainer Ring data sheet.
 For correct sprocket position: See uni Assembly Instructions for uni CPB.
 For more detailed sprocket information, contact Customer Service.



Expert advice, quality solutions and local service for all your belting needs
www.ammeraalbeltech.com

Ammeraal Beltech Modular A/S
 Hjulmagervej 21
 DK-7100 Vejle

T +45 7572 3100
 F +45 7572 3348
 admin@unichains.com
 www.unichains.com

This information is subject to alteration due to continuous development. Ammeraal Beltech will not be held liable for the incorrect use of the above stated information. This information replaces previous information. All activities performed and services rendered by Ammeraal Beltech are subject to general terms and conditions of sale and delivery, as applied by its operating companies.