

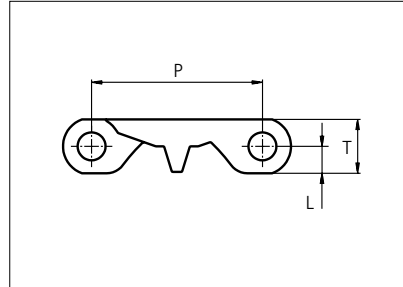

Plastic Modular Belt

Series **uni MPB** Type **18%**



Straight running belt
 Nominal pitch: 50.8 mm (2.00 in)
 Surface type: Flat
 Surface opening: 18%
 Backflex radius: 65.0 mm (2.6 in)
 Pin diameter: 8 mm (0.31 in)

Belt material & color	POM-DI W	PP W	PE-I N	PP-HW LB		mm	in		mm	in	
	Pin material & color					P (Nominal)	50.8	2.00	T	16.0	0.63
	PP W		PE W	PP-HW LB		L	8.0	0.31	-	-	-

Non standard material and color: See uni Material and Color Overview.

Alternative pin and lock materials: Pin: PA6.6 **N** PP **W** PE **W** PBT **LG** SS304 Lockpin: PA6.6 **B** PBT **LG** Trilock: PA6.6 **N**

Belt width		Permissible tensile force (Belt/pin material)						Belt weight (Belt/pin material)						*Min. No. drive sprocket per shaft	Number of wear strips (Min. No.)	
		POM-DI/PP		PP/PP PP-HW/PP-HW		PE-I/PE		POM-DI/PP		PP/PP PP-HW/PP-HW		PE-I/PE			**Carry (pcs)	**Return (pcs)
mm	in	N	lbf	N	lbf	N	lbf	kg/m	lb/ft	kg/m	lb/ft	kg/m	lb/ft			
68	2.7	1870	420	1088	245	884	199	0.8	0.51	0.5	0.34	0.5	0.37	2	2	2
84	3.3	2307	519	1342	302	1091	245	0.9	0.63	0.6	0.42	0.7	0.45	2	2	2
151	5.9	4153	933	2416	543	1963	441	1.7	1.13	1.1	0.76	1.2	0.81	2	2	2
185	7.3	5075	1141	2953	664	2399	539	2.0	1.38	1.4	0.93	1.5	0.99	2	2	2
202	8.0	5555	1249	3232	727	2626	590	2.2	1.51	1.5	1.02	1.6	1.09	2	2	2
252	9.9	6930	1558	4032	906	3276	736	2.8	1.88	1.9	1.27	2.0	1.35	2	2	2
302	11.9	8305	1867	4832	1086	3926	883	3.4	2.25	2.3	1.52	2.4	1.62	3	3	2
353	13.9	9708	2182	5648	1270	4589	1032	3.9	2.63	2.6	1.78	2.8	1.90	3	3	2
403	15.9	11083	2491	6448	1450	5239	1178	4.5	3.01	3.0	2.03	3.2	2.17	3	3	2
453	17.8	12458	2800	7248	1629	5889	1324	5.0	3.38	3.4	2.28	3.6	2.44	4	4	2
504	19.8	13860	3116	8064	1813	6552	1473	5.6	3.76	3.8	2.54	4.0	2.71	4	4	2
554	21.8	15235	3425	8864	1993	7202	1619	6.1	4.13	4.2	2.79	4.4	2.98	4	4	2

Additional standard belt widths are available in steps of 50.3 mm (1.98 in.) Additional non-standard belt widths are available in steps of 16.8 mm (0.66 in.)

1963	77.3	53983	12135	31408	7061	25519	5737	21.8	14.64	14.7	9.89	15.7	10.55	14	14	7
------	------	-------	-------	-------	------	-------	------	------	-------	------	------	------	-------	----	----	---

Additional standard belt widths are available in steps of 50.3 mm (1.98 in.) Additional non-standard belt widths are available in steps of 16.8 mm (0.66 in.)

2970	116.9	81675	18361	47520	10682	38610	8680	33.0	22.16	22.3	14.97	23.8	15.97	20	20	10
------	-------	-------	-------	-------	-------	-------	------	------	-------	------	-------	------	-------	----	----	----

General belt tolerance is +0/-0.4% at 23°C/73°F and 50% RH. For exact belt width contact Customer Service. Non standard belt width on request.

*Max. Load per Drive Sprocket. Belt material: POM-DI with snub roller 2000 N (450 lbf) without snub roller 1250 N (281 lbf).

**Max. Spacing between wear strips, Carry: 152 mm (6 in); Return: 304 mm (12 in).

= Single Link



STANDARD

STRAIGHT RUNNING

PITCH 50.8 MM/2.00 IN

Accessories

Rubber Top

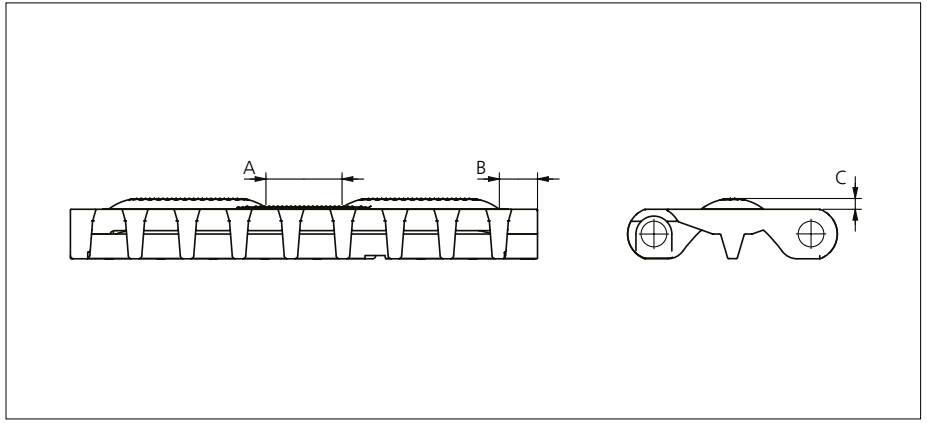

Type	Belt Material & color	Rubber Material & color	A		B		C		Link size	Width	
			mm	in	mm	in	mm	in		mm	in
Curved Rough	POM-DI W	01 N	24.0	0.94	10.0	0.39	3.5	0.14	K600	151.0	5.94

Non Standard material and color: See uni Material and Color Overview.

Accessories

Flight



See separate uni MPB series Flight datasheet.

Accessories

Side Guard

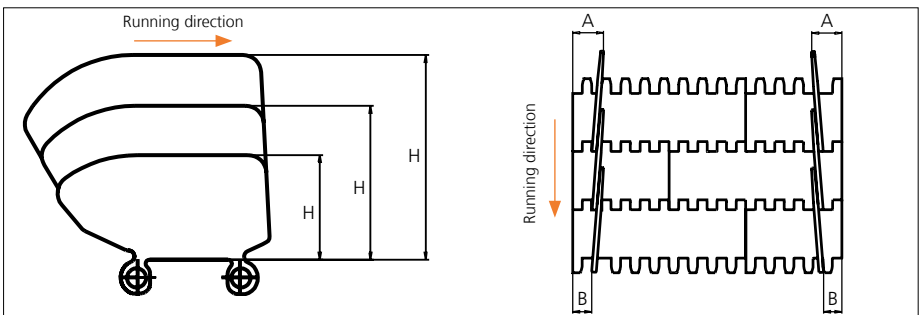

Type	Side Guard Material & color	H		A		B	
		mm	in	mm	in	mm	in
Closed	PE-I B N PP-I W B	50.8	2.00	32.0	1.26	16.0	0.63
		76.2	3.00				
		101.6	4.00				

*34.0 mm (1.34 in) combined with flight. Increment: 8.4 mm (0.33 in).

Note: Backflex radius when Side Guards are used: 200.0 mm (7.90 in)

Accessories

Tab

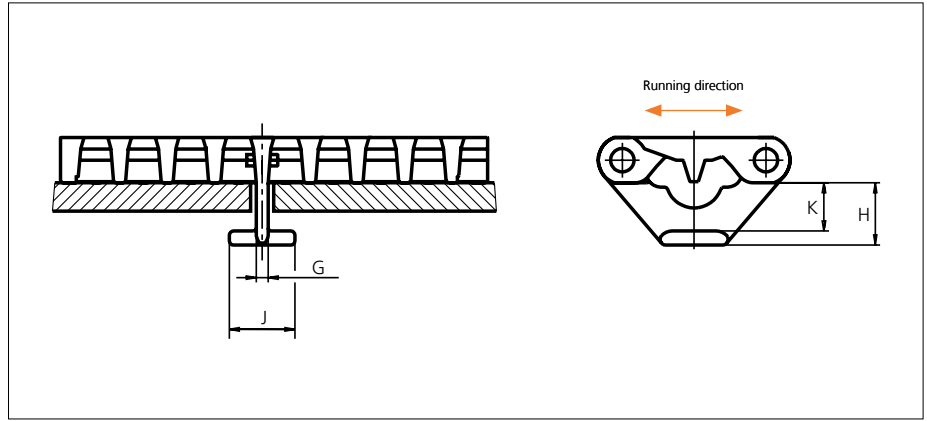

Type	Tab Material & color	G		J		K		H	
		mm	in	mm	in	mm	in	mm	in
Bottom Hold Down	POM-DI w	4.2	0.17	23.2	0.91	17.0	0.67	22.0	0.87

Note: When using tabs, please verify sufficient clearance to the shaft. Max. shaft diameter = Sprocket pitch diameter - 63.5 mm (2.50 in). When using square shafts, please verify that the diagonal does not exceed max. diameter. Example: Sprocket z = 6: Max. shaft diameter 101.6 - 63.5 = \varnothing 38.1 mm (4.00 - 2.50 = \varnothing 1.4 in).

Note: When using a belt system with tabs, the temperature should be constant. Please note that the tabs are not always placed in the middle of the belt.

Non Standard material and color: See uni Material and Color Overview.

Accessories

Non standard uni AmFlight

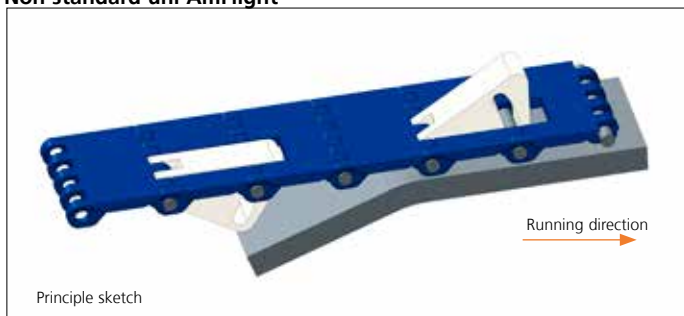

Other non standard option: See uni AmFlight Overview.

Sprocket

No of teeth	Bore size										Overall diameter		Pitch-diameter		Hub-diameter		Dimension A		Dimension B		Single row/One way	Double row/Two way	Molded PA6 LG	Machined PA6 N
	Pilot bore		1.00		1.18		1.25		1.50															
	mm	in	25.4	30.0	31.8	38.1	40.0	60.0	63.5	90.0	mm	in	mm	in	mm	in	mm	in	mm	in				
Z06	✓	●	●	●	■	●	■				99.5	3.92	101.6	4.00	65.0	2.56	36.0	1.42	59.3	2.33	✓	✓		
Z08	✓	●	●	●	■	●	■	■			132.9	5.23	132.8	5.23	70.0	2.75	53.3	2.10	74.9	2.94	✓	✓ ¹	✓	
Z10	✓		●	●	●	■	■	■	■	■	166.3	6.55	164.4	6.47	¹ 70.0 ² 120.0	2.75 4.72	70.2	2.76	90.7	3.57	✓	✓	✓	
Z12	✓		●	●	●	■	■	■	■	■	198.6	7.82	196.3	7.73	¹ 70.0 ² 120.0 ³ 164.0	2.75 4.72 6.45	86.8 86.8	3.42 3.42	106.6 106.6	4.19 4.19	✓ ¹⁺²	✓ ²⁺³	✓	
Z16	✓		●	●	●	■	■	■	■	■	263.8	10.39	260.4	10.25	¹ 150.0 ² 164.0 ³ 200.0	5.90 6.45 7.87	119.7	4.71	138.7	5.46	✓ ¹	✓ ²⁺³	✓	✓

● Molded sprocket ■ Molded sprocket ■ Machined sprocket



Other sprocket sizes are available upon request.
 Other bore sizes on sprockets are available upon request.
 Round bores are always delivered with keyway.
 Max. load per sprocket shown does not take bore size into account.
 Please also ensure that sufficient size shaft is chosen for corresponding load.
 Width of tooth = Single row: 9.5 mm (0.37 in)
 = Double row: 17.8 mm (0.70 in)
 Width of One-part sprocket = Single row: 42.3 mm (1.66 in)
 = Double row: 42.3 mm (1.66 in)
 = ³Double row: 50.0 mm (1.96 in)

uni UltraClean Two-Part Sprocket

No. of teeth	Bore size				Overall diameter		Pitch-diameter		Hub-diameter		Dimension A		Dimension B		Single row/One way	Moulded PA6 W
	in	1.50	1.57	2.36												
	mm	38.1	40.0	60.0	mm	in	mm	in	mm	in	mm	in	mm	in		
Z8		■	■		132.9	5.23	132.8	5.23	80.0	3.15	53.3	2.10	74.9	2.94	✓	✓
Z10		■	■	■	166.3	6.55	164.4	6.47	¹ 126.0 ² 118.0	¹ 4.96 ² 4.65	70.2	2.76	90.7	3.57	✓	✓
Z12		■	■	■	198.6	7.82	196.3	7.73	¹ 126.0 ² 118.0	¹ 4.96 ² 4.65	86.8	3.42	106.6	4.19	✓	✓

■ Moulded uni UltraClean TwoPart Sprocket

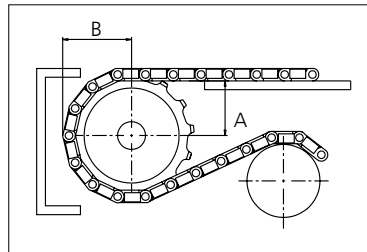

Width of UltraClean Two-part sprocket = Single row: 44.0 mm (1.73 in)
 Width of UltraClean Two-part sprocket, tooth = Single row: 9.5 mm (0.37 in)

uni Retainer Rings: See uni Retainer Ring data sheet.
 For correct sprocket position: See uni Assembly Instructions for uni MPB.
 For more detailed sprocket information. contact Customer Service.

uni MPB 18/2019:03:04



Expert advice, quality solutions and local service for all your belting needs
www.ammeraalbeltech.com

Ammeraal Beltech Modular A/S
 Hjulmagervej 21
 DK-7100 Vejle

T +45 7572 3100
 F +45 7572 3348
 admin@unichains.com
 www.unichains.com

This information is subject to alteration due to continuous development. Ammeraal Beltech will not be held liable for the incorrect use of the above stated information. This information replaces previous information. All activities performed and services rendered by Ammeraal Beltech are subject to general terms and conditions of sale and delivery, as applied by its operating companies.