

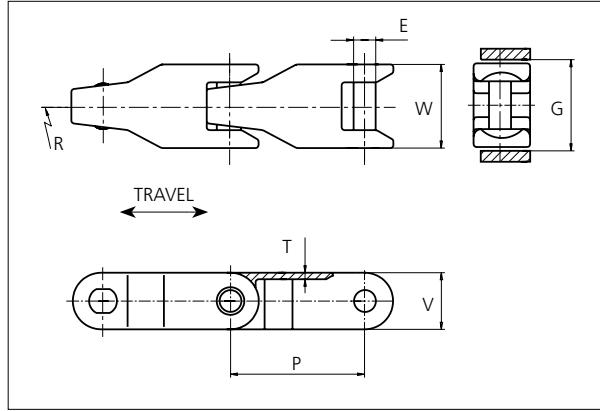

# uni Flex Plastic Chain

Series **uni 2600** Type **C**



**uni Flex Plastic Chain**  
 Side flexing chain  
 Pitch: 63.5 mm (2.50 in)  
 Backflex radius:  
 75.0 mm (3.00 in)  
 Permissible tensile strength:  
 POM material 4500 N (1012 lbf)  
  
 Standard shipping lengths:  
 boxes of 96 links  
 = 6.096 m (20.0 ft)

STANDARD

E		G		P		T		V	
mm	in	mm	in	mm	in	mm	in	mm	in
11.0	0.43	44.5	1.75	63.5	2.50	3.5	0.14	28.4	1.12

All dimensions are for chains in POM material.

Nominal width (W)		Material & color	Pin material	Weight		Min. radius (R)	
mm	in			kg/m	lb/ft	mm	in
42.0	1.65	POM-D <b>W</b> <b>G</b> <b>B</b>	<b>SS431</b>	1.4	0.94	600.0	23.62

Non standard material and color: See uni Material and Color Overview.

Non standard pin material: See uni Material and Color Overview.

SIDE FLEXING

## Accessories

### Rubber Top

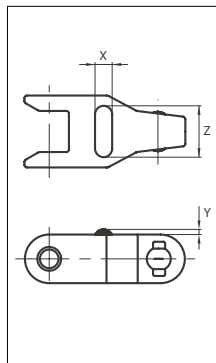
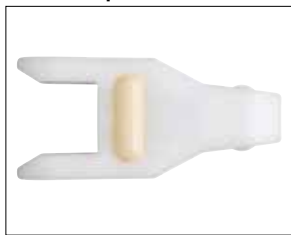

Link material	Rubber material	Z		X		Y	
		mm	in	mm	in	mm	in
POM-D <b>W</b>	05 <b>I</b>	30.0	1.18	10.0	0.39	3.0	0.12

When ordering, please state the required distance between the Rubber Top.

Other Non Standard rubber profiles:  
 See uni Rubber Profile Overview.

PITCH 63.5 MM/2.50 IN

## Sprocket

No of teeth	Pitch diameter		Overall-diameter		Min. ø bore		Max. ø bore		Hub-diameter		Dimension A		Dimension B		PA6	Cast iron	SS304
	mm	in	mm	in	mm	in	mm	in	mm	in	mm	in	mm	in	Molded	Molded	Machined
Z6	127.0	5.00	128.0	5.04	20.0	0.79	40.0	1.57	63.0	2.48	40.8	1.61	78.1	3.07	✓	✓	
Z8	165.9	6.53	168.9	6.65	20.0	0.79	50.0	1.97	73.5	2.89	62.5	2.46	97.5	3.84	✓	✓	✓
Z10	205.5	8.09	210.5	8.29	20.0	0.79	50.0	1.97	73.5	2.89	83.5	3.29	117.2	4.61	✓	✓	
Z11	225.4	8.87	231.4	9.11	20.0	0.79	50.0	1.97	73.5	2.89	93.9	3.70	127.1	5.00	✓	✓	

Non standard material and color:  
See uni Material and Color Overview.

### Machined sprocket



### Cast iron sprocket



### SS304 sprocket

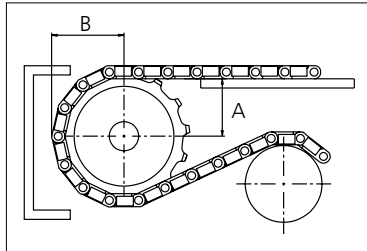

Please ensure that sufficient size shaft and keyway are chosen for corresponding load.

Other sprocket sizes are available upon request  
Width of tooth: 11.0 mm/0.43 in  
Width of sprocket: 42.3 mm/1.66 in  
Width of cast iron sprocket: 41.3 mm/1.63 in  
uni Retainer Rings: See uni Retainer Ring data sheet

uni 2600 C/2021.08.23



Synthetic Belts



Endless Woven Belts

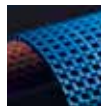

Modular Belts



Engineered Belts



Homogeneous Belts



Fabrication & Service

Expert advice and quality solutions  
for all your belting needs.  
ammeraalbeltech.com

**Ammeraal Beltech Modular A/S**  
Hjulmagervej 21  
DK-7100 Vejle  
T +31 7572 3100

**ammega.com**

This information is subject to alteration due to continuous development. Ammeraal Beltech will not be held liable for the incorrect use of the above stated information. This information replaces previous information. All activities performed and services rendered by Ammeraal Beltech are subject to general terms and conditions of sale and delivery, as applied by its operating companies.

Member of Ammega Group.