

uni NTB Engineering Guideline

Table of Contents

Introduction	2
Transfer edges	2
Nose bar transfer	2
Roller transfer	2
Knife edge transfer	3
Driving the belt	4
One directional conveyor with small transfer zones	4
Centre / Omega drive	5
Traditional end drive	6
Guiding the belt	7
Guiding by U-profile	7
Guiding by sprockets	7
Positions of sprockets	7
Sliding sheets	8
Materials for uni NTB	8
Further support	8

Introduction

uni NTB Closed

The uni NTB Closed is a new belt series providing the smallest pitch for the modular product family. With a 8 mm pitch focus is on tight transfer applications, serving numerous segments, with bakery being primary focus. By introducing this new belt, we close a gap in our portfolio, emphasizing our One Stop Belt Shop strategy.

Design

The belt is designed with a closed, flat and non-stick mat top surface. The design is made with focus on cleanability, ensuring that the belt has a closed surface that does not open even when turning at the nosebar. By that crumbs, dirt and debris are prevented from engaging with the belt. Equally, the bottom surface is with a very open design, exposing both the pins and the belt bottom surface for efficient cleaning. The belt comes with a range of sprockets, designed to give sideways support to the belt to avoid side tracking.

Application

Application focus is for transfer of light and delicate products. It is able to run over a nose bar with a nose radius of just 3 mm. The modular belt will reduce service and down time required to adjust and align flat belts, and further eliminating the problem of fraying.

Transfer edges

Nose bar transfer

With a nose bar the front flex radius can be reduced as a function of the belt pitch. The preferential way is to build with a nose bar as explained here. As uni NTB is designed with just an 8mm pitch, it is specifically designed for use with nose bar. It has a profile on the bottom of the modules so they contour better to the nose bar. uni NTB is designed to run over a nose bar with a radius of only 3 mm (see sketch).

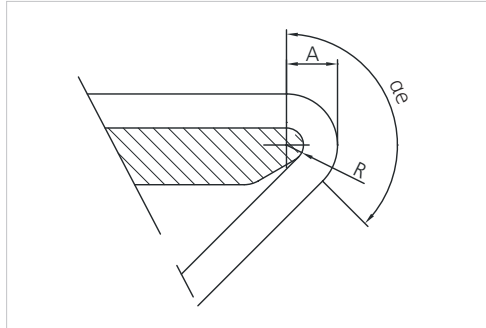
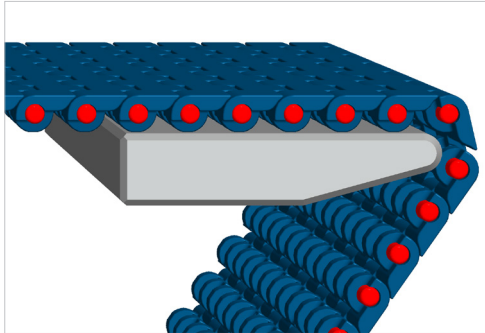

	mm	in
A min	9.0	0.35
R min	3.0	0.12
αe	100-120°	

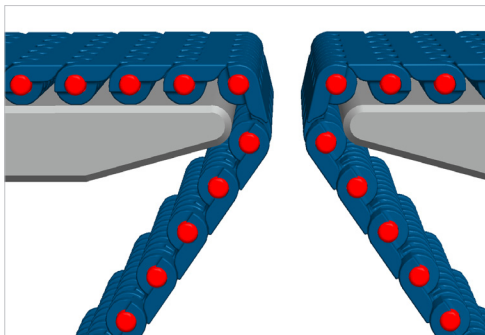

The more wrap the belt needs to be with more tension. The less wrap the better, recommend in the range of 100-120° wrap. It is our recommendation to have nose bars made of nylatron.

Roller transfer

On conveyors with center/omega drive it's normal to use rollers in both ends of the conveyor to reduce the transfer zone. When using the uni NTB belt you can reduce the size of the rollers to $\varnothing 6$ mm (0.24 in). Due to the deflection of such a small roller this can only be used for narrow belts.

The advantage of using rotating roller is that the rollers will rotate with the belt which will reduce the tension in the belt, the wear on the belt and noise generated from the rollers. When using rotating rollers in both ends you will be able to run the belt at very high speed. Speed up to 120 m/min will in many cases be possible but it depends of the load on the conveyor. Please contact Ammeraal Beltech Modular A/S for technical advice regarding load and speed relations (PV-limit).

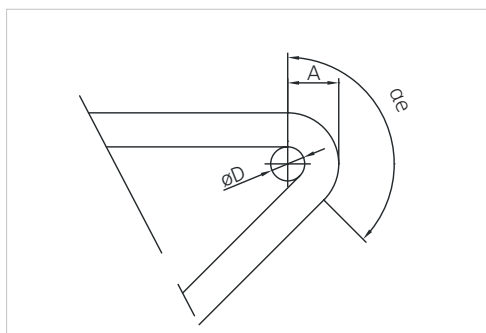
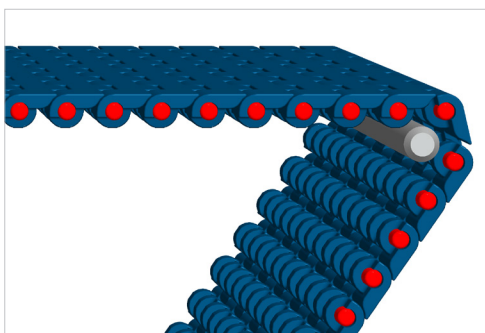

	mm	in
A min	9.0	0.35
R min	3.0	0.12
αe	100-120°	

Special attention needs to be paid to the potential deflection of the roller when small transfer is needed.

Knife edge transfer

Transfer of small products between traditional conveyors can be solved by mounting a small uni NTB conveyor with knife edge transfer between the two conveyors. Knife edge conveyor is a conveyor with center/omega drive where the belt is running over a very small radius and turns 180° so the total height of the conveyor in both ends is reduced to a minimum which allow the conveyor ends to run over the two traditional conveyors. See picture and sketch below.

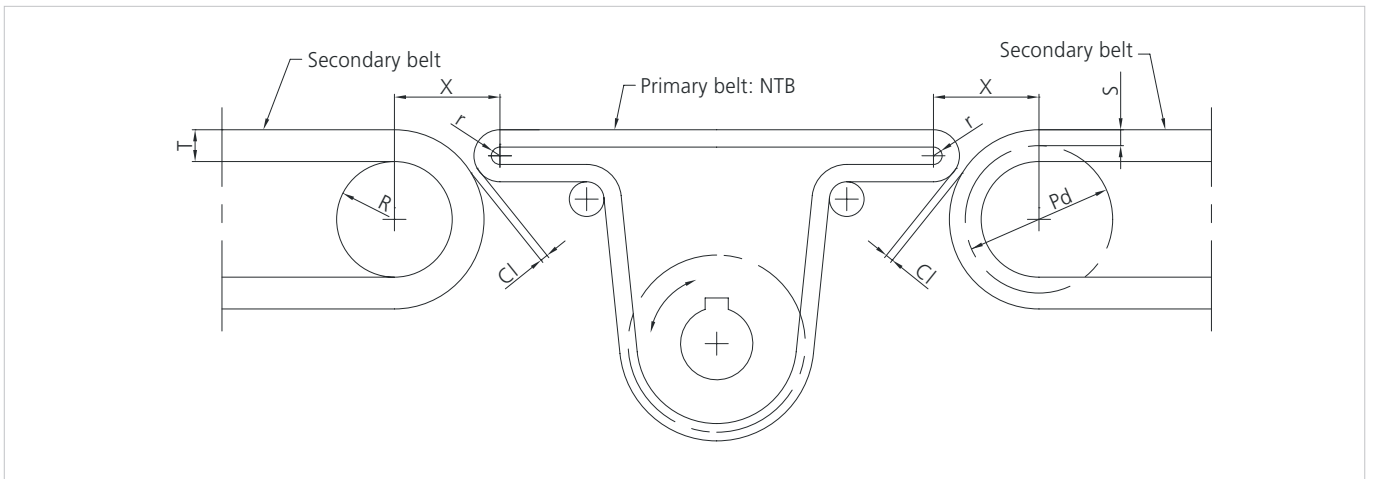
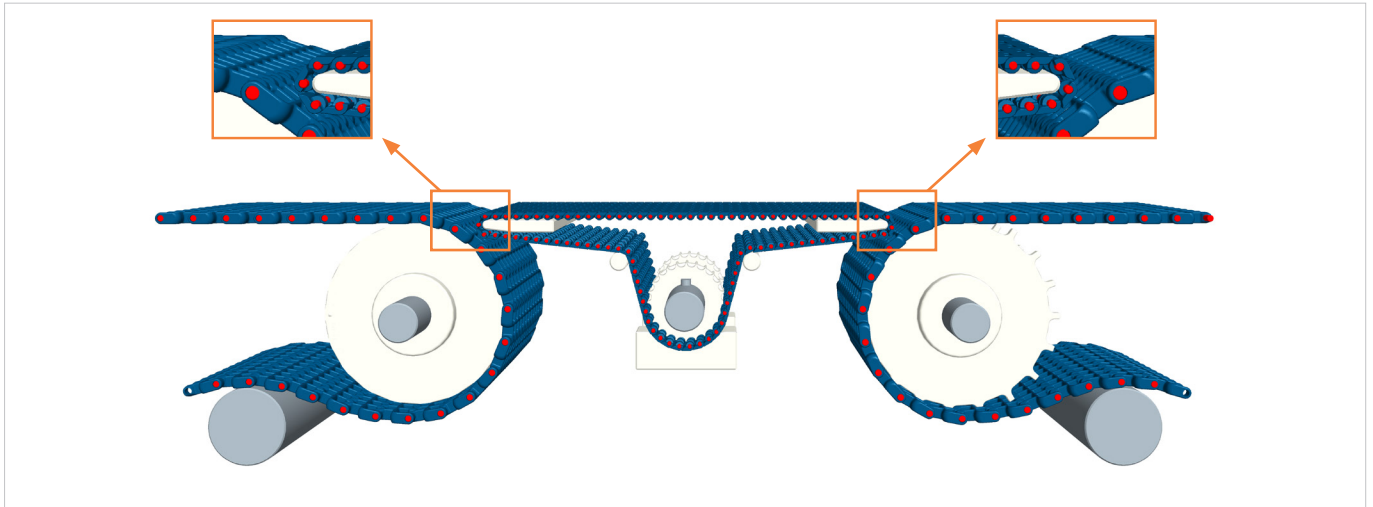

Secondary Belt			
Pitch		Cl	
mm	in	mm	in
8.0	0.31	2.0	0.08
12.7	0.50	4.0	0.16
19.1	0.75	6.0	0.24
25.4	1.00	8.0	0.31
38.1	1.50	12.0	0.47
50.4	2.00	16.0	0.63
63.5	2.50	20.0	0.79

Depending of the type of ends on the traditional conveyor the minimum dimension (X) can be calculated by using these formulas:

$$X = \sqrt{(Pd/2+S+(r+6))^2 - (Pd/2+(S-(r+6)))^2} + Cl$$

Conveyor end on traditional conveyor is with rollers or nose bars:

$$X = \sqrt{(R+T+(r+6))^2 - (R+(T-(r+6)))^2} + Cl$$

The recommended clearance (Cl) can be found in table to the left.

Driving the belt

One directional conveyor with small transfer zones both ends

This is the preferential way of driving the belt.

On one directional conveyor with uni NTB where small transfer zone is needed at both ends the drive motor can be placed as shown below. Note that due to the nature of the belt, the catenary sag is rather light. So option is to use a tension roller.

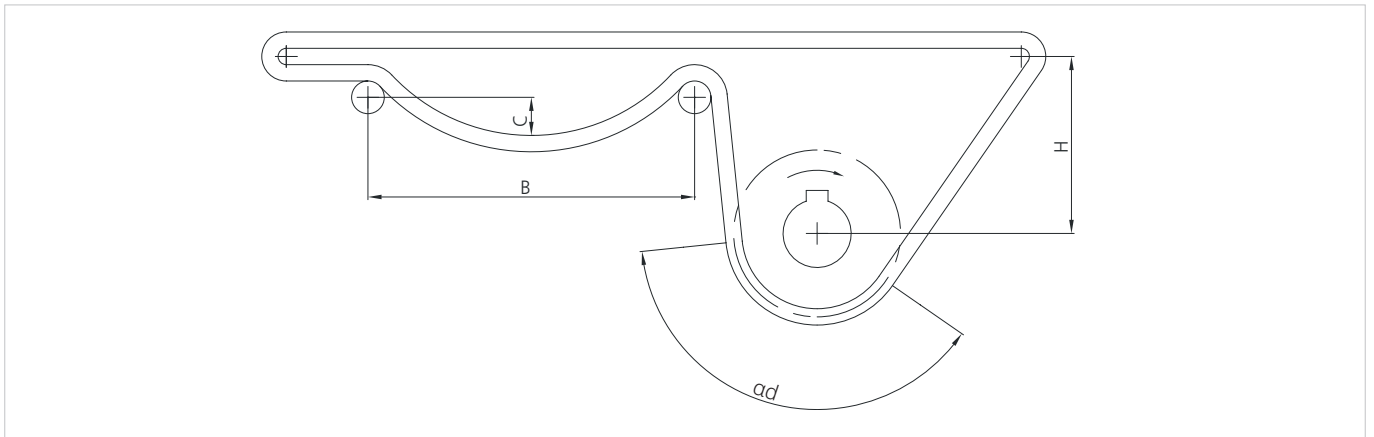
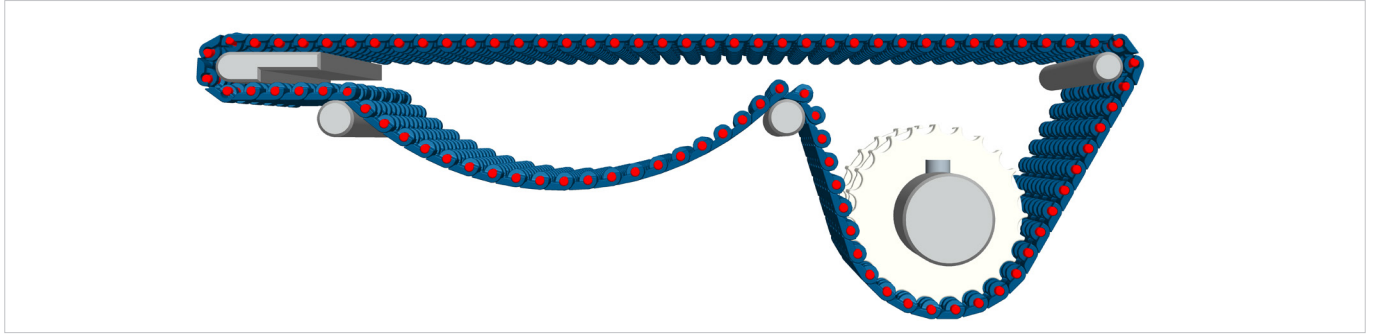

	mm	in
B	150-500	6-20
C	25-100	1-4
H	min 50	min 2
α_d	120°-175°	120°-175°

Center/Omega drive

A very common way of making conveyors with small transfers is to use conveyors where the drive motor is mounted below the conveyor. One way of doing this is to make the conveyor with center/omega drive where the drive motor is placed between two supports as shown on below sketch.

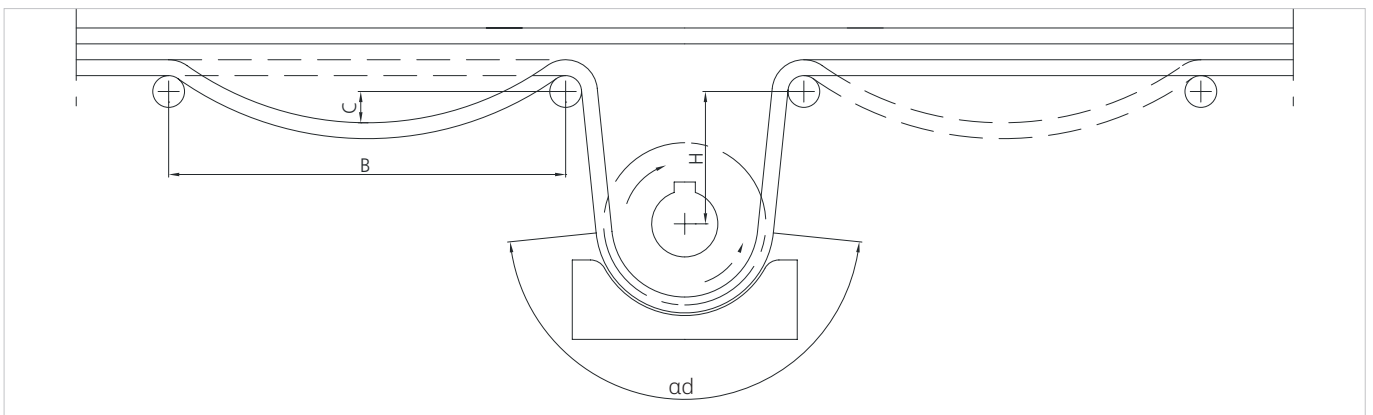
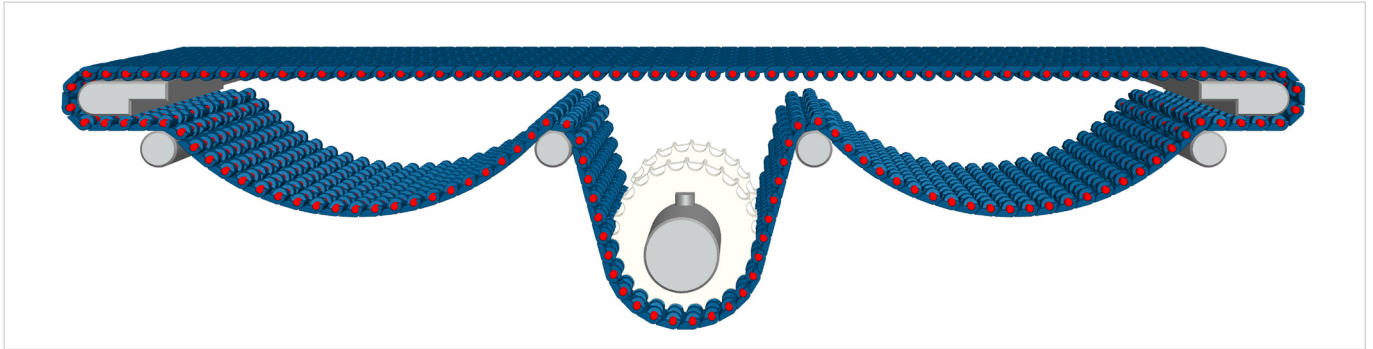

	mm	in
B	100-300	4-12
C	25-100	1-4
H	min 50	min 2
ad	120°-175°	120°-175°

The advantage of this type of conveyor is that you can run both directions with the same drive motor just by changing the running direction of the drive motor. When using center/omega drive the gravity will try to pull the belt of the sprocket opposite normal conveyor with end drive where the gravity will pull the belt down to the sprocket.

Ammeraal Beltech Modular A/S recommend that the wrapping angle between the drive sprocket and the belt is between 120° and 175°. If the wrapping angle is below 120° the risk of disengagement is too high. If the wrapping angle is more than 175° there will be a risk that the belt will not come off the sprocket on the return side and the belt will start to vibrate.

Ammeraal Beltech Modular A/S recommends conveyors with center/omega drive designed according to recommendations in table to the left.

Because gravity will try to pull the belt of the sprocket there will be a risk that the sprocket will lose engagement and the belt will start to jump. To avoid this Ammeraal Beltech Modular A/S recommends using some kind of support below each sprocket.

The belt can be held tight towards the sprocket by means of a shoe that will prevent the belt from jumping out of the sprocket. For each application it should be considered whether this solution is applicable, as this can potentially leave marks on the upper surface of the belt as the shoe is static towards the belt.

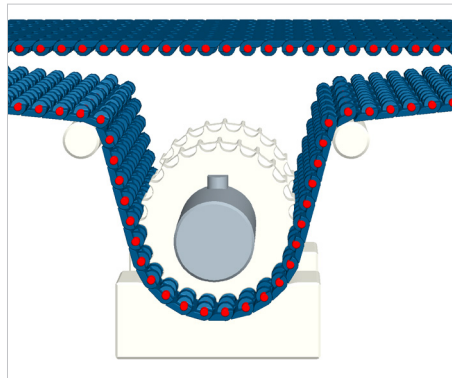

A different option is to use rollers to keep the belt engaged with the sprocket. Again, for each application it should be considered whether this solution is applicable. With the rollers rotating, this option will allow less impact to the upper surface. Further, it is a more cleanable solution.

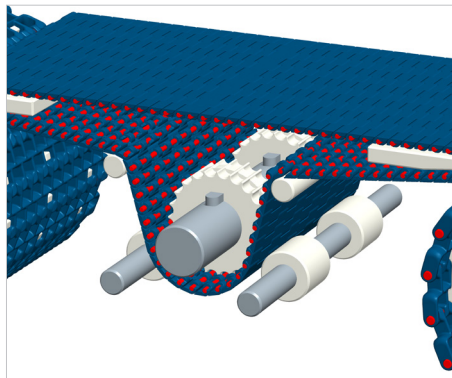

Traditional end drive

uni NTB conveyors can be made with traditional end drive as shown on below sketch.

	mm	in
A	100-500	6-20
B	100-300	4-12
H	25-100	1-4

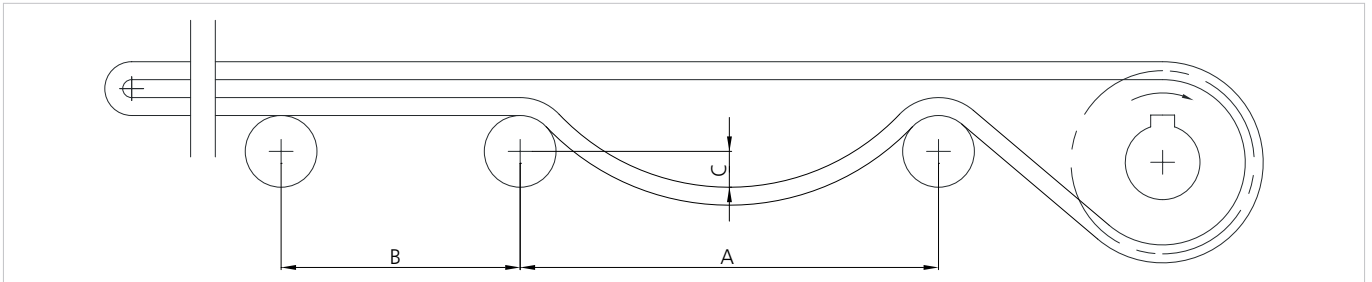
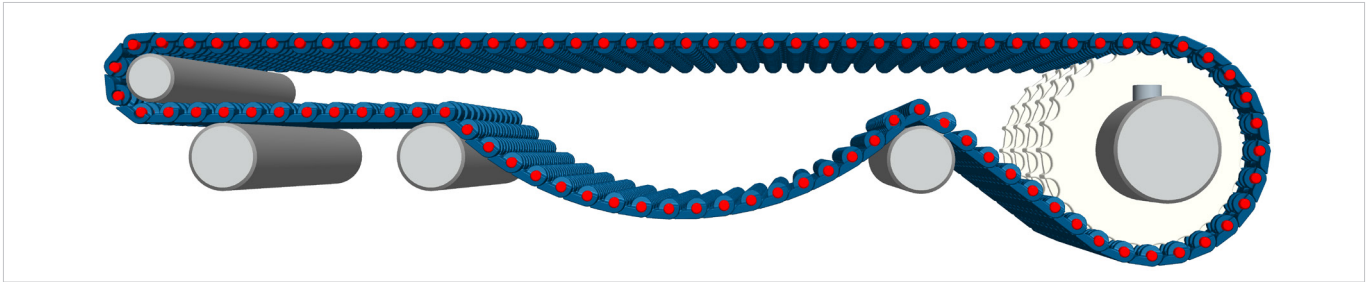

Guiding the belt

As this belt in its nature is small, its lateral stability is low. It is therefore essential that the belt is supported at the carry section. Further, the belt should be supported sideways. Various options for doing that is advised in the next sections.

Guiding by U-profile

The belt is supported at the carry way by a plate underneath the belt.

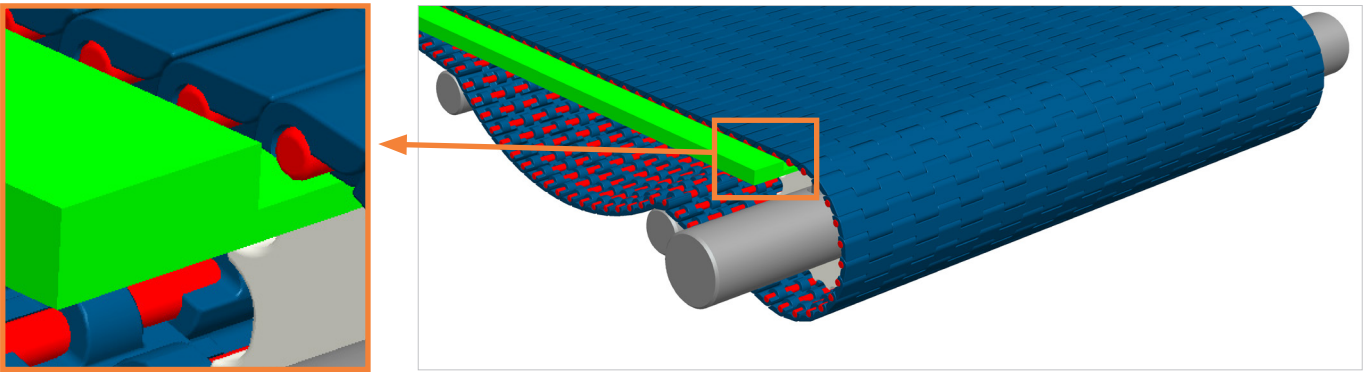
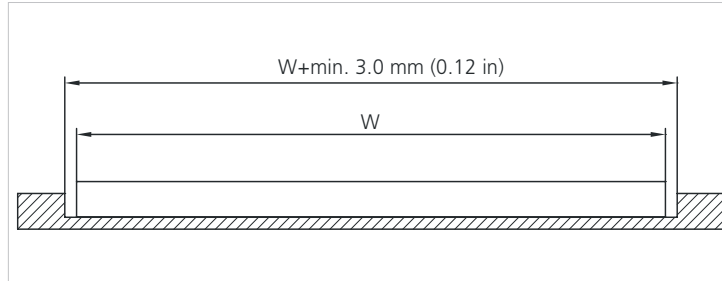

Guiding by sprockets

The sprockets for uni NTB are designed with a center bar. So essentially, the sprocket is a two row sprocket with a bar at the center. The center bar engages with the belt, ensuring that sideways tracking is not possible.

Please note that only having the sprocket to control sideways movement of the belt will only work for very short conveyors. For longer belts further means are needed to control the conveyors, e.g. guiding by side guards.

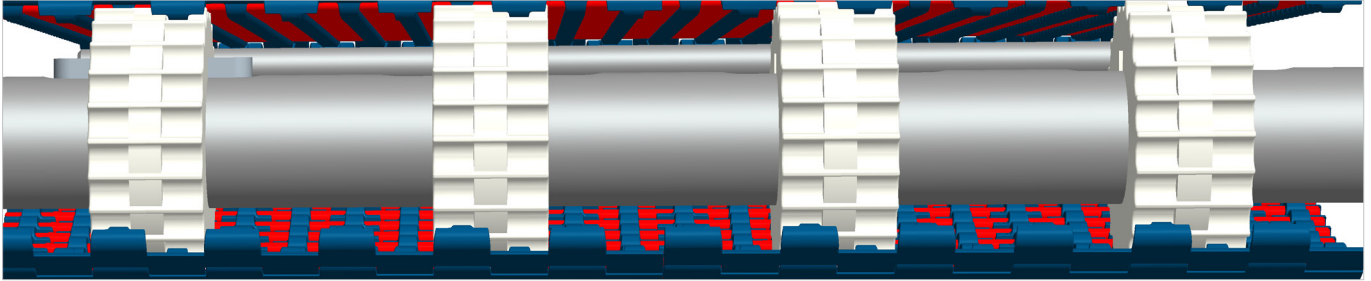

Positions of sprockets

Sprockets can be placed every 12.7 mm (0.50 in) on the entire belt width. Ammeraal Beltech Modular A/S recommend minimum one drive sprocket every 100 mm (4 in) in the belt width. In the return end one sprocket every minimum 150 mm (6 in) is recommended.

The number of sprockets and the distance between the drive- and idler sprockets depends on the types of load on the belt so above recommendations are only guidelines.

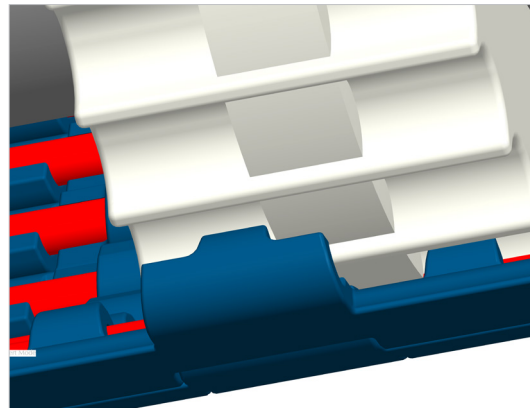
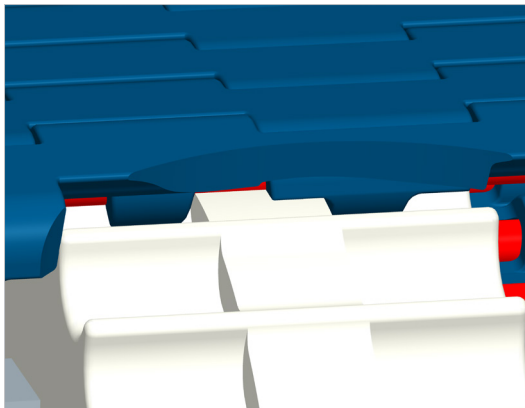

Sliding sheets

Most common construction is a flat polyethylene sliding sheet. Optional the nose bars are machined in the sheet itself.

Materials for uni NTB

- The belt is available in POM with pins in PA66. Both the belt and the pins are standard in blue.
- POM is a thermoplastic material with very good mechanical and thermal properties. The material can also be characterized by great strength, stiffness and dimensional stability. POM is resistant to a wide selection of chemicals. POM has low coefficient of friction and good resistance to wear.
- For uni NTB the POM-D version is used, which includes self-lubricating components.
- Polyamide PA66 is a thermoplastic material. The combination of mechanical properties and chemical resistance make this material suitable for many applications. Polyamide has high resistance to wear and dynamic load.

Further support

For any further support, please consult our technical support staff at your local Ammeraal Beltech office. Please see details of contact on the rear side of this guide. Also you can find more engineering guide lines in our general purpose Engineering Manual, which you will find at www.unichains.com

Local Contacts

... and 150 more service contact points
at ammeraalbeltech.com

Argentina

T +54 11 4218 2906
info-ar@ammeraalbeltech.com

Australia

T +61 3 8780 6000
info-au@ammeraalbeltech.com

Austria

T +43 171728 133
info-de@ammeraalbeltech.com

Belgium

T +32 2 466 03 00
info-be@ammeraalbeltech.com

Canada

T +1 905 890 1311
info-ca@ammeraalbeltech.com

Chile

T +56 2 233 12900
info-cl@ammeraalbeltech.com

China

T +86 512 8287 2709
info-cn@ammeraalbeltech.com

Colombia

T +57 1 893 9890
info-co@ammeraalbeltech.com

Czech Republic

T +420 567 117 211
info-cz@ammeraalbeltech.com

Denmark

T + 45 7572 3100
info-dk@ammeraalbeltech.com

Finland

T +358 207 911 400
info-fi@ammeraalbeltech.com

France

T +33 3 20 90 36 00
info-fr@ammeraalbeltech.com

Germany

T +49 4152 937-0
info-de@ammeraalbeltech.com

Hungary

T +36 30 311 6099
info-hu@ammeraalbeltech.com

India

T +91 44 265 34 244
info-in@ammeraalbeltech.com

Israel

T +972 4 6371485
info-il@ammeraalbeltech.com

Italy

T +39 051 660 60 06
info-it@ammeraalbeltech.com

Japan

T +81 52 433 7400
info-jp@ammeraalbeltech.com

Luxembourg

T +352 26 48 38 56
info-lu@ammeraalbeltech.com

Malaysia

T +60 3 806 188 49
info-my@ammeraalbeltech.com

Mexico

T +52 55 5341 8131
info-mx@ammeraalbeltech.com

Netherlands

T +31 72 57 51212
info-nl@ammeraalbeltech.com

Peru

T +51 1 713 0069
info-pe@ammeraalbeltech.com

Poland

T +48 32 44 77 179
info-pl@ammeraalbeltech.com

Portugal

T +351 22 947 94 40
info-pt@ammeraalbeltech.com

Singapore

T +65 62739767
info-sg@ammeraalbeltech.com

Slovakia

T +421 255648542
info-sk@ammeraalbeltech.com

South Korea

T +82 31 448 3613-7
info-kr@ammeraalbeltech.com

Spain

T +34 93 718 3054
info-es@ammeraalbeltech.com

Sweden

T +46 (0) 10 130 96 00
info-se@ammeraalbeltech.com

Switzerland

T +41 55 2253 535
info-ch@ammeraalbeltech.com

Thailand

T +66 2 902 2604-13
info-th@ammeraalbeltech.com

Turkey

T +90 232 877 0700
info-tr@ammeraalbeltech.com

United Kingdom

T +44 1992 500550
info-uk@ammeraalbeltech.com

United States

T +1 847 673 6720
info-us@ammeraalbeltech.com

Vietnam

T +84 8 376 562 05
info-vn@ammeraalbeltech.com

**Expert advice, quality solutions
and local service
for all your belting needs**

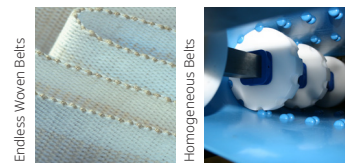
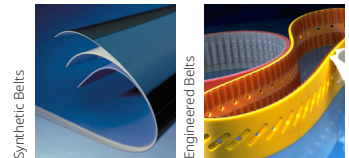

General contact information:

Ammeraal Beltech
P.O. Box 38
1700 AA Heerhugowaard
The Netherlands

T +31 (0)72 575 1212
info@ammeraalbeltech.com

ammerga.com